

Brownfields Remediation

in Delaware County, PA

**Environmental Studies Capstone
Seminar**

Spring 2009

Swarthmore College

Swarthmore, PA



Table of Contents

| | | |
|-------|--|----|
| I. | Introduction to Brownfields | 3 |
| II. | Types of Brownfields | 6 |
| III. | General Steps in the Remediation Process | 9 |
| IV. | Brownfields Funding | 13 |
| V. | Brownfields Law | 17 |
| VI. | Technical Approaches | 22 |
| | A. Site Assessment | 23 |
| | B. Site Investigation | 26 |
| | C. Contaminant Management | 29 |
| VII. | Brownfields in Delaware County | 39 |
| | A. Superfund Sites | 39 |
| | B. Resource Conservation and Recovery Act | 63 |
| | C. Hazardous Site Response Action | 81 |
| | D. Federal Military Cooperative Multi-Site Agreement | 83 |
| VIII. | Summary and Conclusions | 89 |
| IX. | References and Resources | 90 |

I. Introduction to Brownfields

What is a brownfield?

According to the United States Environmental Protection Agency (EPA), the general definition of a *brownfield* is “a property on which the expansion, redevelopment, or reuse may be complicated by the presence, or perceived presence, of contamination.”¹ While the level of hazard or contamination can vary, it can affect all aspects of the local environment, including the land, water, air, and the livelihood of the surrounding inhabitants: humans and wildlife. The EPA estimates that there are currently over 450,000 of these sites in the United States alone, though other estimates show numbers over one million.² Upon discovering these sites, organizations such as the EPA begin a process of potential remediation, where hazardous contamination is assessed and removed in an effort to preserve the safety and health of the surrounding environment. As we will see, many factors and stakeholders comprise the remediation process, often making these processes lengthy and expensive. In order to successfully remediate current and future brownfield sites, it is necessary to understand the history of brownfields in the United States and the process by which remediation occurs.

Why is this issue important?

Perhaps one of the most important reasons why brownfields are relevant to study is that all members of a community can be affected by the successful or unsuccessful remediation of these sites. Left untouched, contaminants from these sites will not only harm those who live, work, or play nearby, but can cause hazards for a much larger surrounding area, such as when contaminants seep into water sources or pollute the air. Economically speaking, brownfields are responsible for an undervaluing of “as much as \$2 trillion of real estate... due to the presence of contamination.”³ Remediation of these sites benefits the health and longevity of the environmental and social community at hand. This is especially relevant for residents of Delaware County, where we have identified over thirty brownfield sites, in conjunction with numerous lingering issues of environmental justice.

In a more positive light, a successful remediation project can revive its community by redeveloping the site into public parks for recreation, or into shopping centers and housing complexes to stimulate the economy. Organizations such as the American Institute of Architects (AIA) have been strong supporters for Brownfield legislation, since they see the economic and social benefits that can be reaped from redevelopment.⁴ Most

¹ Anatomy of Brownfields Redevelopment, 2006.

² National Brownfields Associations (NBA) Press Release, 2009.

³ Ibid.

⁴ Eben, 2008.

importantly, the health and safety of the residents are secured when a site has been addressed.

History

In the 1960s and 1970s, chemical dumping occurred illegally and irresponsibly in many areas of the U.S. Not knowing the consequences, companies wanted their chemical wastes to be disposed of cheaply, which often meant that they would dump chemicals into non-designated areas such as rivers, or store the chemicals in unsafe containers that could leak. This habit finally came to public attention in the late 1970s when two particularly significant cases shed light on the dangers of this practice. The most famous case is the story of Love Canal, a small community built on top of an old toxic waste site. In the late 1970s, the town reported an unusually high number of miscarriages, birth defects, and rare diseases. It became apparent after scientists researched the area that these genetic mutations were caused by the residents' exposure to the toxic chemicals that had seeped into the ground and the town's water supply. President Jimmy Carter declared a state of emergency, and from this tragic case the Comprehensive Environmental Response, Compensation, and Liability Act (CERCLA) was passed in December of 1980, commonly known as the Superfund Act.⁵

More locally, another case that remains salient is that of the Wade warehouse, which was a site located in Chester, PA, along the Delaware River waterfront. In February of 1978, a fire erupted in an illegal hazardous chemical dump on the Wade site that devastated the lives of hundreds in the community, especially the lives of emergency workers responding to the blaze. The chemicals they were exposed to in this environmental catastrophe have been linked to many of the early deaths of over 200 of these firefighters, police officers, and EMT's, who have died from statistically rare diseases such as melanoma, Lou Gehrig's disease, and various cancers. While remediation of the Wade dump site has been deemed a success, the aftermath still lives with the emergency workers alive today and the families of those who have died.

From the devastation of these cases, new legislation and programs were developed to address the need for greater regulation of brownfields in society. The EPA's Brownfield's Program began in 1995 and is "designed to empower states, communities, and other stakeholders in economic redevelopment to work together in a timely manner to prevent, assess, safely clean, and sustainably reuse brownfields."⁶ Starting off with small amounts of money, the EPA supported "pilot" projects, in order to assess which techniques for remediation were most effective. With the passage of the Small Business Liability Relief and Brownfields Revitalization Act, the EPA now has more funds and resources to offer remediation projects, as well as the knowledge of what does and does not work well. This leads to an empowering of the community, which can benefit from the training, knowledge, and funds to redevelop an area.

⁵ EPA, Superfund: 20 Years of Protecting Human Health and the Environment, 2000.

⁶ Anatomy of Brownfields Redevelopment, 2006.

Purpose of this Report

The students of the Swarthmore College Environmental Studies Capstone Seminar of Spring 2009 decided to take on this project as a way to try to add some momentum behind the brownfield remediation processes in Delaware County, PA. Many of these sites have either been prone to stalls and delays or have not yet begun, and although some sites have been successfully remediated and can serve as models for those that remain, at present, the requisite willpower and manpower seem to be lacking. Our communities remain infiltrated by these contaminated lands, hurt by years of irresponsible business practices and lax environmental regulations, and still these sites remain as brownfields. It has been all too easy for these brownfield sites to be left as they are, disregarded as wastes of space. We believe that this trend need not continue, and that it is time that something is done about it. We intend for this report to serve not only as a documentation of the history of these lands but also for the people and organizations of Delaware County to use as a practical guide towards envisioning and realizing proactive solutions to improve the land's environmental integrity and revitalize communities through economic development.

II. Types of Brownfields⁷

Oil and petroleum facilities

Natural gas manufacturing

Manufacturing natural gas from coal and oil involves distilling the gases produced by heating coal or oil. Byproducts from this process can include anthracene (a powder), benzene (a toxic and flammable liquid), cresol (a colorless liquid or solid), naphthalene (a white crystalline compound), paraffin (a white, fairly inactive solid), phenol (a white, poisonous compound), toluene (a colorless, flammable liquid), and xylenes (flammable and toxic liquids). Wastewater and waste products are also produced, including coal fines, coal tar, cyanide salts, and hydrogen sulfide gas. These byproducts and waste products can leak into surrounding sediments, surface water, and groundwater.

Gas stations

Spills, overfilling, and leakages can occur at gas pumps, underground storage tanks, piping systems, and service areas at gas stations. These can cause petroleum, benzene, toluene, xylenes, ethylbenzene, lubricants, coolants, and cleaning solvents to contaminate soils and groundwater. Petroleum brownfields sites are some of the most common and easiest to remediate of the different types of brownfields.⁸

Oil production, distribution and recycling

Drilling, refining, storing, transporting, and recycling oil can contaminate soils with a variety of substances used in oil processing. These include oil sludges, acids, metals, benzene compounds, and waste oil additives such as PCBs (toxic and carcinogenic compounds).

Manufacturing

Chemical and dye manufacturing

Chemical and dye manufacturing facilities use a variety of chemicals, including acids, bases, dyes, polymers, plastics, surfactants (wetting agents that reduce surface tension of a liquid), solvents, soaps, and waxes. Facilities often contain above- and belowground storage tanks, waste piles and disposal pits, wastewater treatment plants, and sludge lagoons or settling ponds. These sources of chemicals can contaminate nearby soils and surface waters, even long after facilities become inactive.

⁷ EPA

⁸ Curtis, 2008

Ordnance sites

Ordnance sites are those which produce, construct, stockpile, or discard of military supplies such as explosives and rifle rounds. Chemicals used at ordnance sites are often highly specialized according to the site's specific function. Raw materials, intermediates, final products, and waste products that can contaminate soils and groundwater include phenols, benzenes, nitroglycerin (a flammable and explosive liquid), metals, ethers (flammable liquids), formaldehyde (a colorless, poisonous gas), toluene, ammoniated compounds, and unexploded ordnance.

Other types of brownfields that are former manufacturing facilities include cement plants, electronics manufacturing, iron and steel manufacturing, machine tool industries, pesticide facilities, plastics facilities, pulp and paper mills, and textile mills.

Recycling

Automobile salvage and metal recycling

These facilities recover reusable and recyclable car parts and scrap metal, such as iron, steel, copper, brass, and aluminum. Soils can become contaminated with products of the salvaging and recycling process, including heavy metals, asbestos, PCB oils, hydraulic fluids, lubricating oils, fuels, and solvents.

Drum recycling

Drum recycling involves cleaning, repairing and repainting drums to be reused. Leaking and spilling of the contents left in drums can contaminate soil and groundwater. Many different chemicals are stored in drums, including acids, bases, corrosive liquids, reactive chemicals, flammable compounds, and oils.

Treatment and repair facilities

Metal plating and finishing

These facilities improve the durability, corrosion resistance, or other performance measures of metal products. Materials are cleaned, etched, plated, and finished in a succession of vats. These process vats can spill, leak, or overflow, contaminating soils and groundwater with heavy metals, solvents, and cyanide.

Paint shops and automobile body repair

Paint shops and auto body repair shops can produce contaminants such as toluene, acetone (a colorless, flammable liquid), perchloroethylene (a solvent), xylene, gasoline, diesel fuel, carbon tetrachloride (a colorless, toxic liquid), and hydrochloric and phosphoric acids. These contaminants may leak into soils and groundwater.

Wood preserver facilities

Wood preserver facilities consist of different sites for each stage in the wood preservation process, including wood preparation, treatment, drying, and storage.

Chemicals used in these stages of wood production include creosote (a wood preservative and disinfectant), pentachlorophenol (a wood preservative), and chrome-copper-arsenate solutions for wood treatment. Leaking or spilling storage tanks allow these chemicals to enter the soil and groundwater. In addition, chemicals can drip onto the earth when wood is moved to drying areas, and runoff from contaminated soils can pollute close-by bodies of water.

Miscellaneous

Agri-business

Various businesses involved in food production such as agricultural chemical distribution sites can become contaminated with fertilizers, pesticides, and herbicides. These materials can reach soils in the catchment basin, groundwater, and nearby surface waters. The addition of fertilizers to surface waters can lead to eutrophication, an increase in nutrients, with associated excessive aquatic plant growth, depleted oxygen and negative ecosystem consequences.

Asbestos piles

Mining operations, ship building, industrial and domestic waste disposal, and building foundation excavation can create asbestos piles. Materials containing asbestos that crumble or otherwise cause asbestos to become airborne are particularly dangerous, as asbestos can cause health problems such as cancer when inhaled.

Landfills and dumps

Although landfills are currently only allowed to receive household, yard, construction, and office waste, before 1970, landfills accepted industrial waste and debris. Some landfills thus contain hazardous chemicals, especially if they are older. Both older and newer landfills can have oils, paints, solvents, corrosive cleaners, batteries, and gardening products. These substances can contaminate soils and groundwater, especially when the landfills are poorly built. Landfills can also trap methane gas and hydrogen sulfide in the soil, which at high levels can become explosive.

Rail yards

Rail yards include networks of railway tracks, storage areas, fueling stations, and maintenance sites. Diesel fuel, paint, solvents, degreasing agents, PCB oils, and creosote are used at rail yards and can leak or be spilled or dumped, polluting soils and groundwater. Rail cars carrying other chemicals and substances can spill or leak during unloading and transfer, thus a wide range of substances can be found at rail yards.

Other types of miscellaneous brownfields sites include meat packaging plants, mining sites and wastes, power generating facilities and utilities, quarries, print shops, and radiation mining, refining, and research sites.

III. General Steps in the Remediation Process

A. Stakeholder Meeting

Before any site remediation occurs, it is important for all stakeholders to meet and discuss the objectives for remediation. Oftentimes stakeholders include local, state, and federal governments; local communities; private parties (property owners, neighbors, etc.); and nonprofit organizations.

Table 1: Stakeholders and participants in the redevelopment process *Anatomy of Brownfields Redevelopment* EPA

| Roles and Interests of Participants | | | |
|-------------------------------------|--|--|---|
| Participants | Examples | Role | Interest |
| Property Owner | | Sell or develop the property | <ul style="list-style-type: none"> • Want to receive a fair value of their property depending on the extent of environmental contamination • Want to manage any liability concerns upfront |
| Public-Sector Stakeholders | <ul style="list-style-type: none"> • Local Governments • Community Groups • EPA Grant Recipients • Nonprofit Organizations | Redevelop the property from a community and economic development perspective | <ul style="list-style-type: none"> • Want to see the project succeed in terms of revitalizing blighted properties and generating economic or community growth • May want the successful property assessment, cleanup, and reuse to enhance the community's image |
| Private-Sector Stakeholders | <ul style="list-style-type: none"> • Investors • Lenders • Developers • Insurers | Provide resources to develop the property | <ul style="list-style-type: none"> • Want to see the project succeed in terms of revitalizing blighted properties and generating economic or community growth • Want to earn an appropriate return on investment • May want to tie the property redevelopment into a larger redevelopment plan for the neighborhood or community |
| Other Parties | <ul style="list-style-type: none"> • Attorneys • Environmental Consultants • State and Federal Regulators | Provide technical, regulatory, or other guidance | <ul style="list-style-type: none"> • Want to ensure that the property is cleaned up and safe for appropriate levels of use and/or reuse • Want to alleviate future environmental concerns on the property |

Each stakeholder should have a clearly defined role in the process, for example, designating whom is in charge of progress monitoring or raising funds for remediation. Plans should also be made for subsequent follow up progress report meetings.

B. Site Investigation

Investigating a brownfield can be a lengthy process. Therefore, it can be helpful to investigate using a phased approach. These can be separated into four categories: Historical Research, Site Characterization, Risk Assessment, and Due Diligence.

(1) **Historical Research:** Researching the land usage history of a site includes addressing concerns such as, who were the previous owners? How was the land used previously? Being able to answer these questions can help narrow down the number and type of contaminants that can be found. It also gives a context for the remediation process that can help guide redevelopment or indicate that redevelopment would not be a viable option.

Potentially good historical sources could be public records, such as property titles, local libraries, and interviews with people in neighboring properties. Finding as much relevant background information as possible can help reduce time in other phases of remediation and help inform stakeholders of how realistic their objectives are.

(2) **Site Characterization:** Characterizing the site includes investigating questions such as what kinds of contaminants are present, in what quantity and to what extent? An inaccurate site characterization can lead to inappropriate remedial actions. Therefore, this step needs to be extremely thorough. It can be one of the most expensive and time consuming steps in the remediation process. A good site characterization should incorporate geological data such as geologic formations and site stratigraphy; hydrological data including major water-bearing formations and their hydraulic properties; and of course, site contamination data including the concentration, type, and distributions of contaminants and what pathways exist for the contaminants to travel. Verifying the local regulations governing brownfields with regulatory officials is a critical component during this phase of remediation.

(3) **Risk Assessment:** The risk or impact assessment usually follows after the site characterization. In some cases, however, it is performed in conjunction with the site assessment. It is “a systematic evaluation used to determine the potential risk posed by the detected contamination to human health and the environment under present, possible, and future conditions”.⁹ The EPA and the American Society for Testing and Materials (ASTM) have developed standard procedures for risk assessments. The EPA method was originally developed by the U.S. Academy of Sciences in 1983. It was adopted and modified by the EPA for Superfund feasibility studies and Resource Conservation and Recovery Act corrective measure studies in 1989. The procedure consists of four general steps: (1) hazard identification; (2) exposure assessment; (3) toxicity assessment; and (4) risk characterization. ASTM standard E1739-95 is known as the Guide for Risk-Based Corrective Action (RBCA). This standard is a tiered assessment that was designed to help assess sites that contained leaking underground petroleum storage tanks. However, many regulatory agencies use a modified version of the RBCA even for sites that do not include underground storage tanks. The RBCA approach combines risk and exposure assessment methods with site assessments and remedial activities. Site-specific conditions and risks can be incorporated into the RBCA process to ensure the appropriate remedial measures are taken.¹⁰

⁹ Reddy *et al.*

¹⁰ Risk assessment is still a developing field. There are still many scientific uncertainties and personal judgments that must be made on what is considered an acceptable level of risk.

(4) **Due Diligence:** If a brownfield is to be redeveloped, the economic and legal implications should be evaluated with a due diligence. In addition to the site assessment, the due diligence is useful for identifying the following:

- Potential legal and regulatory requirements and risks;
- Preliminary cost estimates for property purchase, engineering, taxation and risk management;
- and market viability of a redevelopment project.¹¹

C. Develop a Remediation Plan

The phase where a remediation plan is developed can be combined with earlier phases. If different steps in the remediation process can be effectively integrated, then it may be beneficial to do so. There are a number of different methods for remediation, which are discussed in the Technical Approaches section. A major consideration when selecting a remediation plan is whether or not the site is going to be redeveloped. There are different regulations governing to what degree sites must be cleaned before they are suitable for a particular type of redevelopment. For example, in the Wade brownfield more than 5 feet of soil was removed and replaced with a clean top layer of soil and vegetation. The site was approved to become a parking lot, but if it were going to be used as a recreational park, the standards for cleanup would be very different.

D. Redevelopment

Redevelopment plans are often the driving force behind remediation efforts. The stakeholders can be from a variety of different backgrounds. Individuals and groups from the private and public sectors can collaborate to initiate redevelopment. Remediation plans can be one part of the redevelopment plan along with securing financial and contractual agreements. The EPA *Anatomy of Brownfields* publication lays out a clear and concise diagram indicating typical stages of redevelopment.

¹¹ From p.8 of Technical Approaches to Characterizing and Cleaning up Brownfield Sites. (2001) Technology Transfer and Support Division National Risk Management Research Laboratory. U.S. Environmental Protection Agency.



Figure 1: Typical steps in the redevelopment process *Anatomy of Brownfields Redevelopment* EPA

Although the EPA lays out a clear outline for redevelopment, each site may follow a slightly different process. One of the potential concerns with focusing on the redevelopment rather than the remediation process is that once a project becomes economically infeasible, the remediation process may be halted altogether if the site is not designated as an extreme case, such as with Superfunds. A subtle but important distinction should be made between remediation and redevelopment.

IV. Brownfields Funding

There are two major funding sources for brownfield remediation: public and private. Within each type are many different subsets and individual providers. In order to fully utilize these possibilities it is important to investigate a diverse set of funding sources. This chapter outlines available sources and seeks to be a practical guide for groups searching for brownfield funding no matter the state of redevelopment of the site.

Public funding includes a much broader and diverse set of funding sources because support can come from local (city or county), state, or national sources in the form of tax incentives, grants, or technical assistance. The following is a list of federal sources, taken directly from a document compiled by Kathryn Whiteman during a 2002 Internal City/County Management Association brownfields conference, which should be considered for Delaware County¹².

- U.S. Department of Commerce:
 - Economic Development Administration (EDA)- planning grants/assistance; infrastructure grants; technical assistance; revolving loan funds; help for economically distressed communities
 - National Oceanic & Atmospheric Administration (NOAA)- Coastal Resource Coordinator Program- assessment and remediation of contaminated coastal sites; Coastal Zone Management Program- funds and tech assistance for feasibility studies, site assessments and master plan development
- U.S. Department of Defense:
 - U.S Army Corps of Engineers- technical engineering assistance; dredging; funds Formerly Used Defense Sites (FUDS)
- U.S. Department of Energy (DOE):
 - Brightfields/renewable energy development, Rebuild America program
- U.S. Environmental Protection Agency (EPA):
 - Pilot programs; assessment grants; Revolving Loan Funds (RLF); Clean up; Job training; Targeted assistance grants; Environmental Justice grants; Brownfields Technical Assistance to Brownfields (TAB) program; State and Tribal Assistance Grants (STAG)
- U.S. Department of Housing and Urban Development (HUD):

¹² Whiteman, 2002

- Community Development Block Grants (CDBG); Section 108; Brownfields Economic Development Initiative (BEDI) funds; Empowerment Zones and Enterprise Communities
- Department of Community Affairs- Planning Assistance
- U.S. Department of the Interior:
 - National Park Service - Land and Water Conservation Fund (LWCF); Rivers, Trails and Conservation Assistance; Urban Park and Recreation Recovery; Federal Lands-to-Parks Program
 - US Fish and Wildlife- technical consultation and assistance regarding habitat restoration or protection and ecosystem conservation; Land and Water Conservation Fund grants
- U.S. Department of Transportation (DOT):
 - Transportation Outreach Program; funds for recreational trails, bicycle and pedestrian projects; funds for ADA compliance; Intermodal Grant Program (parking garage facility, waterfront district); ISTEA/Tea-21
 - Coast Guard- Boating Improvement Program (community boat ramp, canoe launch)
 - Federal Highway Administration (FHWA)- funding and technical assistance to programs to improve interstate highways and affiliated roadways; Transportation and Community System Preservation Pilots; Congestion Mitigation and Air Quality Improvement Program
 - Federal Railroad Administration (FRA)- funding and technical assistance to programs encouraging development or rehabilitation of rail infrastructure and technologies
 - Federal Transit Administration (FTA)- funding and technical assistance to local and regional transit initiatives
 - U.S. Maritime Administration (MARAD)- technical assistance for port facilities and shipyard revitalization
- U.S. General Services Administration:
 - Federal properties discounted up to 100% when transferred to state or local governments through public benefit conveyances
- U.S. Small Business Administration (SBA):
 - Guaranteed loans, financial management, technical and government-contracting assistance to current and prospective small business owners

- Federal Emergency Management Agency (FEMA):
 - Flood Management Programs; Emergency Shelters; Mitigation/ Emergency Planning; Assistance to locate outside of floodplain

At the Pennsylvania state level the Department of Environmental Protection (DEP) provides information, training, and special assistance through the Office of Community Revitalization and Local Governmental Support¹³. There are numerous grant opportunities available at the state level for different types of remediation (see the list and explanations directly from DEP website below). Moreover if a site is dire enough to be considered for the Brownfield Action Team (BAT) then the state offers additional clean up funding.

- *Evaluation for Hazardous Site Cleanup Act (HSCA) Remedial Response*: Provides independent, technical evaluation of proposed remedial response at a HSCA site. The HSCA gives the DEP the funding and authority to intervene and conduct a cleanup of a site where hazardous substances were released and the involved parties are not financially capable of dealing with the problem.
- *Growing Greener Watershed Grants*: Provides funding to restore watersheds and streams, reclaim mined lands, and remediate AMD.
- *Host Municipality Certified Inspectors (Hazardous)*: Awards reimbursement to municipalities for certified inspectors of commercial hazardous waste storage, treatment or disposal facilities.
- *Illegal Dump Cleanup*: Provides financial assistance for a maximum of \$25,000 with a 50% match to assist in the cleanup of illegal dumps on public lands, state-owned lands, and third-party sites.
- *Pennsylvania Energy Harvest Grant*: This grant's goal is to deploy cleaner energy sources that protect water or air quality and have a positive economic benefit. It provides funding for renewable energy deployment; biomass energy projects; coal-mine methane, waste coal reclamation for energy; implementation of innovative energy efficiency technologies; or clean distributed generation infrastructure improvements. Energy Harvest is not a research initiative. It is about new and innovative technologies in the marketplace.
- *Pollution Prevention Reimbursement (Pump & Plug UST)*: Reimburses costs of pumping and plugging storage tanks
- *Technical Evaluation of HSCA Remedial Response*: Independent technical evaluation of proposed remedial response at a HSCA site.
- *Waterline Grant*: Cleanup of contaminated water sources at a HSCA site.
- *Industrial Sites Reuse Program (ISRP)*: Part of the Land Recycling Program, ISRP provides grants and low-interest loan financing for former industrial sites.

¹³ DEP

- *Tax Increment Financing (TIF) Guarantee Program:* Provides \$5 million to individual project and \$100 million statewide, funded through bond issue, as well as offering intensive technical assistance on completing the application.
- *Brownfields Inventory Grants (BIG) Program:* Part of the Land Recycling Program, BIG provides funding to investigate and catalogue brownfields properties and posts them in the State's "PA SiteFinder" database. Grantees receive \$1,000 per site posted.
- *Brownfields Remediation Loan Program:* Grants low-interest loans for clean-up of sites that threaten local groundwater or surface water through PENNVEST.

At the county level, Delaware County offers the *Revitalization Program* through the Office of Housing & Community Development (OHCD). The program provides grant money to townships in the southern and eastern part of the county for revitalization of previously determined brownfield sites¹⁴.

In the private sector the goal is to seek out all liable parties. The first step is to seek monetary compensation, often through the judicial system, from the former owners, polluters, or users. The next step is to try to convince the current owners to pay for remediation. Finally, developers or future owners can be brought in and pay for remediation. It is possible to pass on the costs of redevelopment to future beneficiaries through a flat charge or augmented rent or property sale price.

Securing financing through bank loans is often a crucial element of remediation. Other important sources of investments are outside donors or trusts set up to remediate the land. Private investors could be brought into the process if the redevelopment plans are ambitious and the land is situated in a desirable location. However, these cases are rare as more often than not brownfields are located in disadvantaged areas.

Remediation and redevelopment of brownfield sites benefit communities. Therefore, in some regions non-profits have been created to provide technical support and guidance. The Northeast-Midwest Institute provides assistance through technical support in the form of case studies, networking, resource identification, and legislative support¹⁵. Similarly the non-profit National Brownfield Association provides educational and technical guidance as well as vast networking opportunities for members¹⁶.

¹⁴ Delaware County, 2006

¹⁵ Northeast-Midwest Institute, 2009

¹⁶ National Brownfield Association, 2009

V. Brownfields Law

Introduction:

Begun in 1995, the Brownfields program was spearheaded by the EPA as part of an effort to clean up contaminated properties. Of primary importance was reducing health hazards and allowing for redevelopment of the contaminated properties. We wish first to establish a set of criteria through which we can judge good or bad brownfield law. We draw upon the State Environmental Resource Center's "Features of Good Brownfield Legislation." Good brownfields legislation will:

- Eliminate public health and environmental risks;
- Create incentives for voluntary cleanup and redevelopment and ensure a means of funding;
- Develop protective and consistent cleanup standards;
- Ensure full public involvement and public accountability in the cleanup and redevelopment of contaminated property; and
- Ensure that those responsible for contamination of property are held accountable for their actions.

One of the first brownfields, Love Canal in New York State, illustrates concretely the importance of the criteria for good brownfield-related law.

In the early 1900s, William T. Love envisioned a dream city built on the eastern side of Niagara Falls in New York State. By digging a canal between the upper and lower rivers, he hoped to provide power for the new community. Instead, once Nikola Tesla introduced his alternating current—a cheap method of transmitting electricity over long distances—and due to the state of the economy, Love abandoned his project.¹⁷ In the 1920s, the canal was used as a dumping site for municipal waste as well as industrial chemicals. Later, during the 1950s, homes were built on the site. In 1978, residents raised safety questions and subsequently the dire nature of the situation was publicly exposed.

The cleanup efforts have been extensive and largely cooperative between the local government, the state, and the EPA, which mandated the cleanup.¹⁸ People were successfully evacuated from the area, emergency aid was delivered within the day, and plans have been set in place to clean the area according to EPA standards for clean air and water. However, it is difficult to pinpoint who should be liable for the damage, because so many companies dumped their waste in the canal.

¹⁷ EPA History Love canal <http://www.epa.gov/history/topics/lovecanal/01.htm>

¹⁸ *Ibid.*

Louisville presents a similar case. When a hazardous waste site named the Valley of the Drums situated near the city began leaking chemicals into the water, Louisville worked closely with the EPA through its Superfund program. Land surveys, removal of many drums, and an agreement by Kentucky to operate a treatment plant if the EPA should fund it, are all examples of the successful results of cooperation. The city agreeing to meet the federal EPA halfway is a good example of incentivizing public involvement. But most importantly, both Love Canal and the Valley of the Drums signify the complexity of brownfield law.

Brownfield Law: Four Parties, Four Aspects

Cooperation is a key factor in the remediation process of brownfields. From a legal standpoint, there are four principal parties.

- The polluters
- People residing around the brownfield
- The EPA and Lawmakers
- Individuals or Corporations that wish to build on brownfield sites

The four major parties each have a place in considerations of four aspects of brownfield law, listed below. As such, the law can become rather complicated, especially in regards to liability. Who should pay? For example, the person who ran a chemical facility on the site last, or the three companies, now bankrupt, who began operating on the site decades ago? Sometimes, when the “polluter pays” principle can’t be enforced, the company that operated delivery trucks for the plant might have to pay the cost!

Concurrently, there are four key aspects of brownfields law:

- Liability (who pays for what?);
- Funding (how can we get the money?);
- Removal vs. Remediation; and
- The state of Pennsylvania’s modifications and additions to federal brownfield law what is the law for brownfield cleanup and redevelopment in Pennsylvania?

Liability

Liability is one of the most complex legal challenges involved in Brownfield cleanup and redevelopment. In the end, liability ultimately boils down to who pays for the damage? As was already hinted at above, the question of “who pays” would in theory be very complicated if one were to try and quantify measurable amounts of blame for all salient

parties involved on a particular site. In order to avoid these complexities, the law simplifies the situation for the EPA and other enforcement agencies. When pursuing a removal or remediation action, the EPA may sue to obtain funding from any party involved. Specifically, these include four classes of parties:

- the current owner or operator of the site;
- the owner or operator of a site at the time that disposal of a hazardous substance, pollutant or contaminant occurred;
- a person who arranged for the disposal of a hazardous substance, pollutant or contaminant at a site; and
- a person who transported a hazardous substance, pollutant or contaminant to a site; that transporter must have also selected that site for the disposal of the hazardous substances, pollutants or contaminants.¹⁹

This includes current owner, previous owner, operators, contractors, and other companies conducting business on the facility. In order to facilitate cooperation, a liable company may be fined up to \$25,000 for each day of noncompliance. Let's say for example that in order to fund the cleanup of a particular dumping site, the EPA seeks damages from the previous owner and wins. If the previous owner felt that it was not entirely liable and that another company who conducted business on the site was partly liable as well, then it would be the responsibility of the previous owner to sue the other company in question. However, the process for the EPA is simple—it can go after whomever it deems most appropriate. If the EPA is unable to obtain remedial, monetary damages from any of the involved parties, then it may tap into its own funds in order to facilitate remediation. These rules are a result of the Comprehensive Environmental Response, Compensation, and Liability Act (CERCLA) of 1980, better known as Superfund.

Additionally, under the Resource Conservation and Recovery Act of 1976 (RCRA), enforcement agencies may mandate cleanup actions in the event of an “imminent hazard.” Under RCRA, liability is placed on the current owner(s) or operator(s).²⁰

In the year 2001, Congress passed the “Small Business Liability Relief and Brownfields Revitalization Act.” Among other things, this law amends some of the liability restrictions present under CERCLA in three specific areas. First, innocent purchasers of properties are now generally excluded. Second, bona-fide purchasers may now be able to receive some relief under this new act. Third, owners of contiguous properties who receive contamination from an adjacent property may no longer be liable under CERCLA.²¹

Funding

The law allows enforcement agencies to tap into several sources of funding. First and foremost is a result of the Comprehensive Environmental Response, Compensation, and Liability Act (CERCLA) of 1980, better known simply as Superfund. In addition to

¹⁹ CERCLA, Section 107

²⁰ Davis, 2002

²¹ Bourdeau, 2002

allowing the EPA to pursue parties for damages as outlined above, the crux of this legislation was that it authorized the EPA or other enforcement agency to undertake cleanup on its own, using a specially designated trust fund. In 1986, CERCLA was updated, increasing the size of the fund to \$9 billion.

Removal vs. Remediation

There are currently more than 450,000 brownfields in the U.S. as designated by the EPA.²² This presents to the federal government a large task, involving a staggering cost in both capital and time. Each brownfield project requires assessment of the land, cooperation between the local area and the federal government and state, and buyers. In a case where the brownfield was being developed commercially, it would seem a simple matter to have potential redevelopers assist in funding with the cleanup of the area, because the developers want the land. Yet there are people who live near brownfields not desirable for commercial development, who suffer the health effects of proximity to toxins in the ground and water. In some cases, all that is required is that the area is simply scraped of visible contaminants and fenced off.²³ This can still leave residents near the area vulnerable to toxins leaching into the groundwater.

Citizens living near brownfields desire that the area is safe to live near, but the cost of remediation can soar if people demand that one hundred percent of contaminants be removed. Herein lays the distinction between remediation and removal. Remediation is a process of brownfield cleanup that creates conditions acceptable to human health requirements. Removal is eradicating contaminants as far as possible. For individuals or corporations that are intent on developing the land, they need simply to remediate the land so that it is safe for human beings. But some individuals, feeling unsafe, demand higher standards.

Removal, on the other hand, is legally defined under CERCLA as a short term action to prevent potential harm. A removal action must cost less than \$2 million and be of a duration not to exceed 12 months.²⁴ In the majority of emergency situations, removal will take place prior to remediation.

The extent of cleanup is dependent upon locality. However, issues of locality can become a problem when there is no one found liable for the cleanup costs. If the polluter has moved to another country or is bankrupt, who pays for the cleanup cost?

Brownfield Law in Pennsylvania:

In the state of Pennsylvania, the cost of remediation is ideally shared by various parties. In addition to the developers' partnership, the EPA assists in coordinating Voluntary Cleanup Programs (VCP) to "encourage, assist, and expedite brownfields

²² EPA, "About Brownfields." <http://epa.gov/brownfields/about.htm>

²³Abdel-Aziz. <http://www.osler.com/resources.aspx?id=8530>

²⁴ MIT, 2004.

redevelopment. VCPs streamline brownfields redevelopment, reduce transaction costs, and provide liability protection for past contamination.”²⁵ In other words, brownfield remediation is a cooperative process.

Undergirding these partnerships are “environmental covenants,” which were signed into law on December 18, 2007 as Act 68, the Uniform Environmental Covenants Act (UECA).²⁶ This harmonized state and federal laws concerning environmental cleanup, making it easier to track which parties were or were not maintaining cleanup efforts. It also created a standard document that all parties involved in the cleanup would have to sign in order to ensure fair liability. In this way, the PA Department of Environmental Protection (DEP) simply acts as an extension of the federal EPA.

²⁵ From p.9 of Technical Approaches to Characterizing and Cleaning up Brownfield Sites. (2001) Technology Transfer and Support Division National Risk Management Research Laboratory. U.S. Environmental Protection Agency.

²⁶ PA DEP, “UECA.” <http://www.depweb.state.pa.us/ocrlgs/cwp/view.asp?a=1459&Q=534040>

VI. Technical Approaches

This section of the report focuses on the approaches and methods utilized to characterize the brownfield site and future possibilities for remediation. Often before this process even begins, brownfield developers will have an idea for the future development of the site—what the final plan for the land will be. This provides the framework for how in depth and precise the site assessments will need to be, and will determine the level of cleanup and remediation needed. With this framework, the site assessment and investigation processes will generate the data required to make an informed decision on how to proceed with cleanup and redevelopment.



Figure 2 Flow chart of the redevelopment process²⁷

²⁷ EPA, 2001.

A. Site Assessment, Phase I

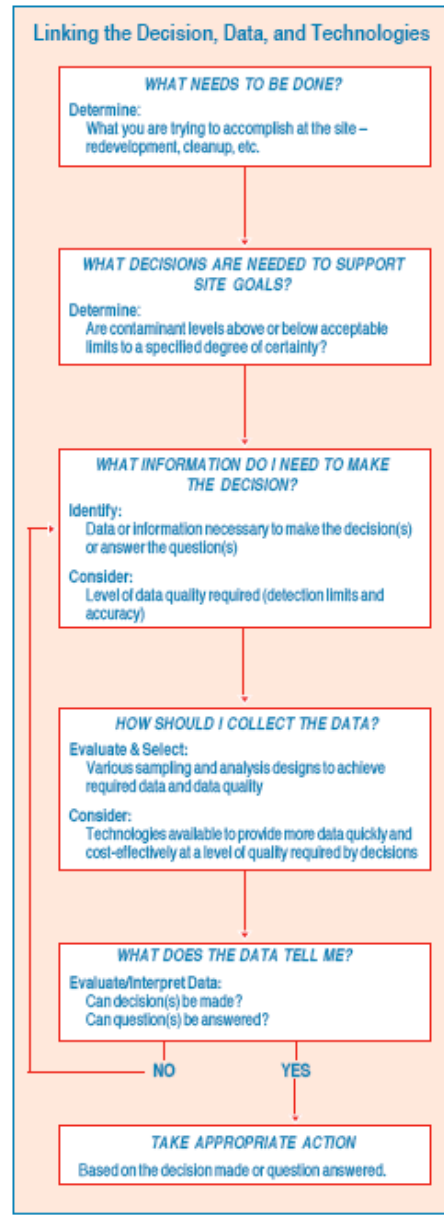

Figure 3. Linking the decision to redevelop to the site assessment process²⁸

Once a brownfield site has been identified, the first step is to evaluate the potential contamination. A Phase I Environmental Site Assessment (ESA) is performed to identify potential concerns, which will then be confirmed by Phase II Environmental Site Assessment with sampling and laboratory analysis. The data collected in this process must

²⁸ EPA, 2005.

thoroughly discern the past and current environmental conditions of the site in order to accurately determine what future investigations or remediation will be required. This is the most crucial step in the brownfield process, because all further environmental investigation and cleanup will depend on whether potential environmental concerns have been correctly identified.

The purpose of Phase I ESA is to obtain a geographic inventory of all the features and conditions of potential environmental concern. A feature is an object, such as an old underground storage tank, that may have been a source of contamination. A condition is the environmental impact associated with the feature, such as soil or groundwater contamination. In addition to providing information regarding the feasibility of the redevelopment project, the Phase I ESA is conducted alongside a due diligence analysis.²⁹ The purpose of the due diligence process is to determine the risks associated with the brownfield project by conducting market, financial, and legal liability analyses. Together, site assessment and due diligence paint a comprehensive picture of the possible liabilities in property ownership.

The Phase I ESA consists of obtaining general property information, historical records, and performing non-intrusive site evaluations. The American Society for Testing and Materials (ASTM) standards are widely used guidelines for conducting assessments of commercial and industrial properties (ASTM E1527-05)³⁰. Past owners and uses of the site can be identified by reviewing tax documents, aerial photographs, as well as fire, police, and health department documentation of the property. City government and other historical records can be used to determine past use or disposal hazardous waste materials at the site. Federal and state lists identify sites that may have environmental contamination and should be thoroughly reviewed ³¹(CERCLIS, see Resources). In addition, property owners, occupants, previous employees, local planners, and residents should also be interviewed.

The data collected provides information on discontinued operations and demolished structures where the contamination may have originated. Particularly vital is the determination of whether chemical substances were leaked and when that leakage began—a barely detectable leakage may be negligible in the context of a single week, but over the course of months or years, there is the possibility for groundwater contamination or a buildup in toxicity. Through a Phase I ESA, an inventory will be generated for:

- storage tanks (aboveground and underground)
- use and storage of hazardous materials
- generation, storage, and disposal of hazardous wastes
- polychlorinated biphenyls (PCBs)
- asbestos
- wastewater
- other environmental concerns

²⁹ Refer to Section III on due diligence.

³⁰ ASTM, 2005.

³¹ EPA, 2008.

Table 2 The advantages and disadvantages of standard historical research materials³²

| Research Material | Advantages | Disadvantages |
|--|---|---|
| PHOTOGRAPHS | | |
| Aerial photographs ¹ | Unbiased images of physical reality, usually available from multiple sources | Usefulness may be limited by small scale, poor clarity, or obscuring vegetation |
| Ground-level photographs | Scale and closeness of view | Rarely available |
| NON-PHOTOGRAPHIC DEPICTIONS | | |
| Plans and drawings ² | Site specific; the most detailed source of information | Unless a plan or drawing is labeled "as built," uncertainty may arise as to whether the plan or drawing depicts what was intended to be built or what actually was built |
| USGS topographic maps ³ | Availability | Scale and infrequency of revision |
| Geologic quadrangle maps ⁴ | Depict quarries and pits that may have become landfills | Relatively few historic geologic quadrangle maps were prepared |
| Fire insurance maps ⁵ | Very valuable; depict features (storage tanks, substations, transformer vaults, etc.), note operations (painting, fueling, plating, etc.), and portray interior building spaces | Poor clarity of the electronic versions provided by commercial vendors, and, like any map, fire insurance maps only show what the surveyor identified and the mapmaker decided to include |
| Street maps and atlases ⁶ | More commonly available than fire insurance maps | Much less technical detail than a fire insurance map |
| Navigation charts ⁷ | Useful for identifying waterfront facilities and the possible placement of fill along shorelines | Not readily available |
| Promotional plans and maps ⁸ | Plans and maps prepared for the promotion of local industries or specific industrial projects can be very useful | Not common |
| TEXTUAL MATERIALS | | |
| City directories ⁹ | Very valuable, especially if all three sections are included (alphabetical listing by business name, listing by business category, and block-by-block listing of occupancy by street address) | The information is only as good as the canvassers and compilers were diligent, and company names do not necessarily indicate the actual nature of the operations |
| Telephone directories ¹⁰ | A useful alternative to city directories, especially if the classified business section is included | Produced as throw-away items on inexpensive and therefore frail paper, telephone directories are not as common as hard-cover city directories |
| Business directories ¹¹ | Useful for identifying and categorizing manufacturers | Not common |
| Real estate directories ¹² | Useful for identifying property owners in time | Not common |
| Geotechnical reports | Logs prepared for foundation engineering studies may indicate the presence of fill or waste deposits | Not often available |
| Company-employee periodicals ¹³ | May include photographs of facilities, descriptions of operations, locations of structures, etc. | Usually limited to large manufacturers |
| General industry publications ¹⁴ | Useful for generic information | Not site specific |
| Government publications ¹⁵ | Official accounts of major projects and programs | Not common or readily available |
| Public records and reports | Fire departments, building departments, and other local governmental offices may have useful information | Municipal records may be discarded after a set period of time or may be archived and not readily available |
| Company archives and histories ¹⁶ | May include photographs of facilities, descriptions of operations, locations of structures, etc. | Usually limited to large manufacturers |

³² Berstein, 2006.

Where Do We Go from Here?



| Result of Site Assessment | Course of Action |
|--|---|
| No evidence of contamination is found and there is no reason to suspect other media are contaminated. Concerns of stakeholders have been addressed adequately. | ➔ <i>Discuss results with appropriate regulatory officials before proceeding with redevelopment activities.</i> |
| Contamination is found that poses a significant risk to human health or the environment. | ➔ <i>Contact the appropriate federal, state, local, or tribal government agencies responsible for hazardous waste. Based on feedback of government agency, determine what cleanup levels are required for redevelopment, and proceed to the SITE INVESTIGATION phase.</i> |
| Contamination possibly exists. | ➔ <i>Proceed to the SITE INVESTIGATION phase.</i> |
| Contamination definitely exists, BUT no site investigation has been conducted. | ➔ <i>Proceed to the SITE INVESTIGATION phase.</i> |
| Contamination definitely exists, AND a site investigation has been performed. | ➔ <i>Proceed to the SITE INVESTIGATION phase if additional investigation is needed; otherwise, proceed to the CLEANUP OPTIONS phase.</i> |

Figure 4 Summarizing the possible courses of action following a Phase I ESA³³

B. Site Investigation, Phase II

If potential environmental concerns are identified through Phase I ESA, a thorough site investigation will be performed to confirm, locate, and characterize the extent of the contamination. The site investigation process is also referred to as the ASTM Phase II ESA, because the ASTM E-1903-97 protocol is widely used³⁴. The study of the brownfield site must be detailed enough to determine any possible environmental or health risks, and the results will shape the contaminant management strategy. It is important that planners have a clear long-term goal of the project and what the end use of the site will be

³³ EPA, 2005.

³⁴ ASTM, 2005.

beforehand; this will determine the type, quantity, and quality of data that must be collected. Screening levels, risk-based standards of chemical concentrations that do not pose an unacceptable risk, will need to be established. If onsite contaminant levels exceed the screening standard, further investigation will be needed to determine if cleanup is appropriate. If contaminant concentrations are below the standard for the intended use, no action is required.

During site investigation, field samples (soil, sediment, groundwater, surface water and gas) will be analyzed to characterize the contamination. The migration pathways of the contaminants are also examined, and baseline risk assessments are performed to calculate the risk to human health and the environment. Initial investigation will consist of screening sampling, in which relatively low-cost technologies are used to analyze a limited number of samples taken at the most likely points of contamination. Screening analyses often test for broad categories of contaminants (total petroleum hydrocarbons, instead of specific contaminants such as benzene or toluene), with the purpose of narrowing down the number of samples requiring further, more costly analysis. This second level of analysis is contaminant-specific, affording high quality and specificity, which provides a more in-depth understanding of the contamination at the site.

Below, the report will discuss key technologies in evaluating contamination of air, land, and water in brownfield sites. For a more comprehensive listing of available technologies, please consult Appendix C of the Technical Approaches to Characterizing and Cleaning up Brownfield Sites publication³⁵ or CLU-IN.org³⁶ (see Resources).

Characterization of Gas/Air Contamination

Air contamination can result when contaminants that exist as a gas are mixed or suspended in the air. At a brownfield site, this may occur when gases or particles containing hazardous substances are released from various sources. The contaminants can originate from landfills, explosions and fires, equipment leaks, and other commercial products. Liquid hazardous materials can be exposed to air and evaporate, and contaminants in surface soil can become airborne.

Colorimetric tests are frequently used immediately after an initial site characterization, as they afford speed, portability, low cost per sample, and can analyze a wide range of contaminants. These test kits have a wide variety of field applications, and can also be used to assess water and soil quality. Generally, a chemical reaction produces a color, which can be used to qualitatively and semi-quantitatively identify a contaminant. Draeger Tubes employ this method to determine the presence of an airborne contaminant: sealed glass tubes are filled with a reagent sensitive to a target gas, and if the target gas is present in the air sample, a color change will occur in the reagent layer of the tube. Tubes can be used to directly characterize ambient air and soil gas in hazardous waste sites, and can be placed in a tank, sewer, or monitoring well to detect gases and vapors produced by soil, sludge, and groundwater.

³⁵ EPA, 2001.

³⁶ EPA., 2009.

Another method of characterizing air contaminants is open path Fourier transform infrared (OP-FTIR) spectroscopy. OP-FTIR is the most versatile of the open path technologies, with the ability to measure the presence of many chemicals in the air simultaneously. OP-FTIR can also achieve low detection limits in the low parts per billion, meaning that it can detect even small amounts of a contaminant. FTIR spectroscopy is based on Beer's Law in physics, which states that for a constant path length, the intensity of direct light energy traversing a medium diminishes exponentially with concentration. The FTIR instrument measures the intensity of light in the infrared spectrum, using the intensity signature to identify and quantify compounds. An OP-FTIR can detect most gaseous compounds based on this method, with the exception of the noble gases, vapor-phase metals, and homonuclear diatomics (O₂, N₂, Cl₂). OP-FTIR monitoring systems have been used to measure air contaminants in capped landfills, refineries, and industrial wastewater treatment plants.

At the end of the Phase I assessment and Phase II investigation, the brownfield owner should have background information regarding the past and current features of the site, as well as a thorough history of its land use. The investigation process should evaluate data concerning the geologic and hydrogeologic conditions of the site. Analytical data should be generated from soil and ground water samples³⁷. All of the information gathered should provide the owner with a thorough inventory of all the recognized environmental conditions and the extent of the damage on affected media. With all this information, the owner can then decide how to proceed with cleanup or redevelopment.

³⁷ ASTM, 2005.

| Results of the Site Investigation | | Course of Action |
|---|---|---|
| No contamination is found. | ➔ | <i>Consult with appropriate regulatory officials before proceeding with redevelopment activities.</i> |
| Contamination is found BUT does not pose a significant risk to stakeholders' human health or the environment. | ➔ | <i>Consult with appropriate regulatory officials before proceeding with redevelopment activities.</i> |
| Cleanup of the contamination found probably will require a small expenditure of funds and time. | ➔ | <i>Proceed to the CLEANUP OPTIONS phase.</i> |
| Cleanup of the contamination found probably will require a significant expenditure of funds and time. However, contamination does not pose a significant threat to local residents. | ➔ | <i>Determine whether redevelopment continues to be practicable as planned, or whether the redevelopment plan can be altered to fit the circumstances; if so, proceed to the CLEANUP OPTIONS phase.</i> |
| Contamination is found that poses a significant threat to local residents. | ➔ | <i>Contact the appropriate federal, state, local, or tribal government agencies responsible for hazardous waste. If contamination exists at considerable levels, compliance with other programs, such as RCRA and Superfund, may be required.</i> |

Figure 5 Summarizing the possible courses of action following a Phase II ESA³⁸

C. Contaminant Management, Phase III

Once the responsible parties determine the nature of the contamination and the proposed future uses of a site through analytical and investigative methods, they may proceed to explore hazardous waste treatment and disposal technologies for hazard containment. There are numerous site and contaminant specific treatment technologies that can with a high efficiency remove contaminants or stabilize the waste to reduce hazard. The major types of treatment technologies in industrial use are categorized as physical treatment, chemical treatment, biological treatment, and thermal destruction.

³⁸ EPA, 2005.

Each technology has particular applications and economic aspects. Additionally, there are specifics to remediate groundwater and soils. When designing a remediation plan, the responsible party must examine the waste characteristics, the site characteristics, the waste soil interaction, and any other specific considerations such as proximity of the facility to surface water, soil erosion properties, or potential health risks to nearby human communities.

Physical Treatment and Separation Techniques:

Sedimentation/Clarification

This is a process by which hazardous suspended solids are removed from a waste stream through gravity filtration. This is usually done in tandem with a biological or chemical treatment. Sedimentation is often done in a settling tank that employs flocculation, a process in which small particles agglomerate to form larger particles, to enhance sedimentation. The solids that accumulate near at the bottom of the settling tank are subsequently removed.

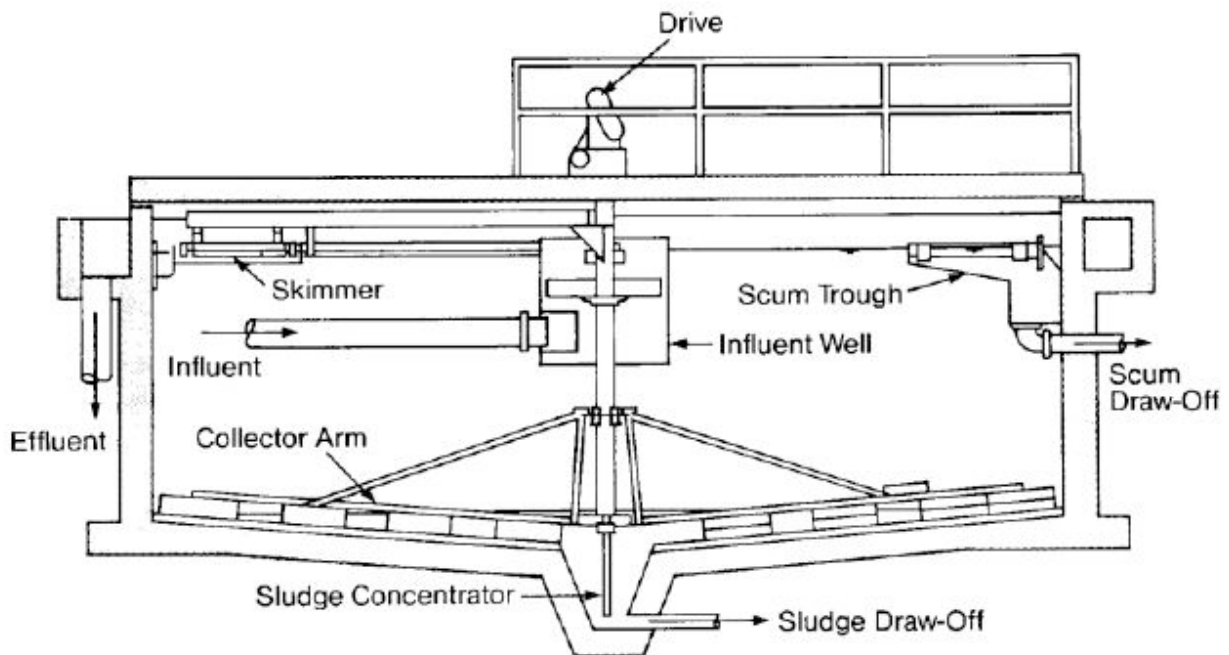

Mechanical clarifier

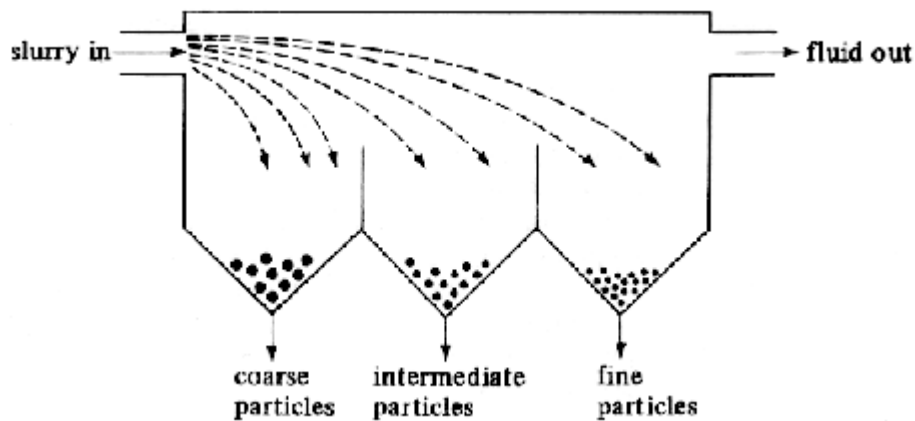

Settling tank

Evaporation

Evaporation is a technique that allows for the separation of volatile compounds from nonvolatile components and is used to remove solvents from solids or semisolids. There are two technologies of evaporation equipment: thin-film evaporators and dryers. Thin-film evaporators have the fluid enter a rotating heated conical receiver and the centrifugal force causes the fluid to travel towards the outer edge where it is collected and drawn off as residue. The volatile components that evaporate from the heating in the process are condensed on a chiller and then collected and contained. Dryers serve as large rotating heated drums that allow volatile compounds to evaporate. For wastewater containing non-volatile compounds and that contains salts or dissolved solids, aqueous evaporation is a technique that minimizes the volume of waste requiring disposal—that is excess water is evaporated in the previous methods to reduce the total volume of the water.

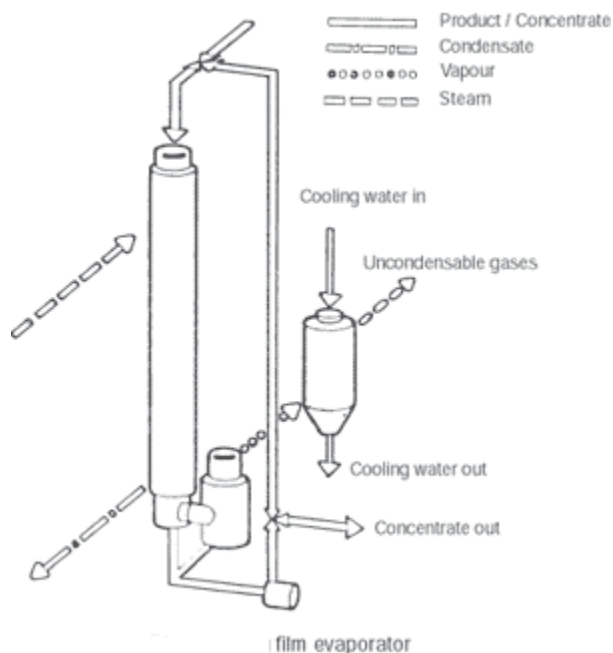

Distillation

Distillation technology allows the operator to remove contaminants from a solvent (i.e. water) waste stream. This technique exploits differences in vapor pressures or boiling points between the water and the impurity. If a volatile compound has a higher boiling point than the water it is dissolved in, the water volatilizes before the impurity, leaving only the impurity.

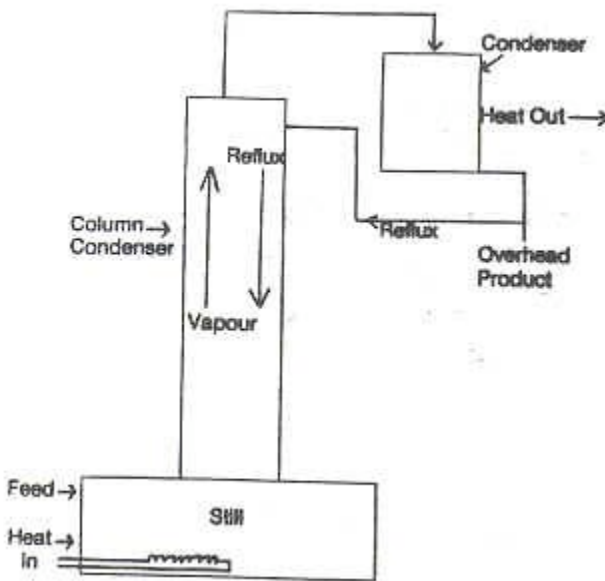

Extraction

The extraction technique is applicable when distillation proves ineffective because the boiling points of the water and the impurity are similar. Extraction is the mixing of a contaminated fluid with an extraction fluid in which the contaminant has greater solubility than within the original solvent (i.e. water). The extract is afterwards sent to a recovery unit for distillation to remove the concentrated hazardous constituent from the solvent such that the solvent may be reused.

Stripping

Stripping is a common technique effective in removing low concentration of volatile organic and inorganic compounds from wastewater. The technology involves passing air or another gas with stripping properties through the liquid. The contaminants are stripped from the liquid phase and are transferred to the gas phase.

Decantation

Decantation is effective in separating two immiscible liquids of different densities. Gravity forces the denser liquid to settle to the bottom of the tank and the less dense liquid rests upon the more dense liquid. Subsequently, the lighter liquid may be extracted from the top while the denser through the bottom of the tank.

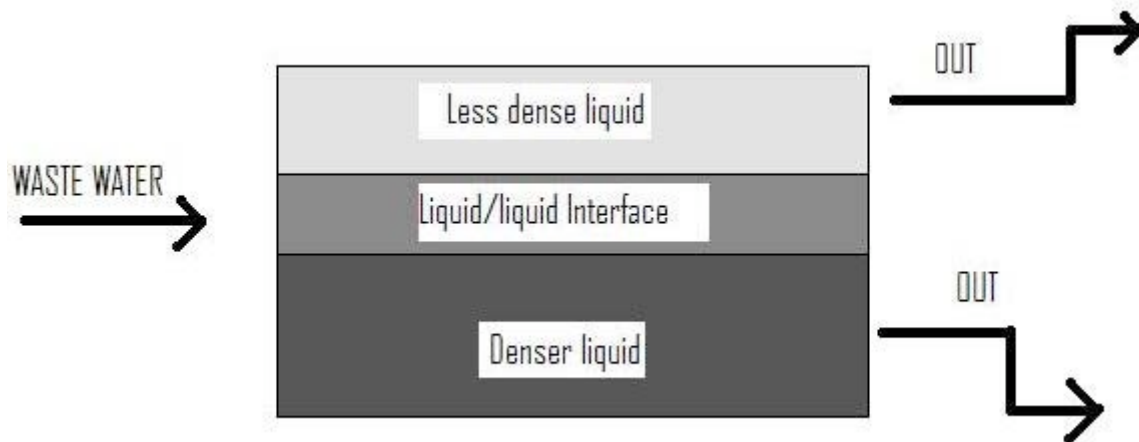

Decantation system

Carbon Adsorption

Carbon adsorption technology can remove dilute organic from a waste stream. This process, similar to a Brita® water filter, uses powdered activated carbon (PAC) to a wastewater effluent in a mechanically agitated tank to maximize contact between the PAC and the wastewater.

Ion Exchange

Ion exchange is the process by which hazardous ionic species within a wastewater effluent are exchanged with non-hazardous ions. This is accomplished via passing the wastewater through a resin bed in a packed column. The ion exchange resin contains mobile ions and cation exchange occurs between the resin and the liquid phase. Ion exchange is effective in removing hazardous metals, fluoride, sulfates, and carbonates.

Solidification/Stabilization Techniques:

Solidification and stabilization is used to render a waste insoluble and immobile or to detoxify it to a less hazardous state. Solidification is the process by which either gas or liquid phase hazardous wastes are converted into solid compounds as to be more stable for landfill disposal. Stabilization involves a chemical reaction that converts the waste to a less hazardous state. The treatment processes that fall in this category often involve both solidification and stabilization and therefore the combination term is employed.

Lime-based and Cement-Based Processes

This technology is applicable to wastes that contain multivalent ions. The lime or the cement acts as a stabilizing medium by which the soluble metal ions precipitate insoluble metal hydroxides. These particles are then bound to the solid matrix of the mixture.

Classification and Vitrification

Classification/vitrification is a process that fuses the wastes into glass or ceramics using extremely high temperatures. This technology is only applicable to wastes that are stable at these high temperatures. The resulting glass/ceramic compound is non-leachable by water and therefore this is effective in immobilizing hazardous wastes.

Chemical Treatment Technologies

Chemical treatment involves exploiting the chemical properties of hazardous wastes and known chemical reactions to reduce the state of the hazardous materials to harmless. This can include acid base reactions, ion reactions, and oxidation-reduction reactions. In the latter, there is either a loss of electrons or gain of an oxygen atom, oxidation, or the gain of electrons or the loss of an oxygen atom, reduction. This process converts the metal to a relatively insoluble metal oxide, hydroxide, or sulfide. The insoluble metal then precipitates out of the wastewater in sludge or sediment that can be treated and either reclaimed or disposed.

Neutralization

A neutralization reaction is one that uses a base to counter act an acidic waste or that uses an acid to neutralize a caustic (basic) waste. Neutralization technology is useful for acidic or caustic wastes.

Chlorination

The practice of adding chlorine to wastewater is an important chemical oxidation technology. The chlorine atoms react with double-bonded carbon compounds to render them less toxic.

Ozonation

Ozonation is a technique where the operator bubbles ozone gas (O_3) through the wastewater. The result is the breakdown of organic compounds including alkanes, alcohols, ketones, aldehydes, phenols, benzene and benzene derivatives.

Electrolytic Recovery

For dealing with metal ions, a cell consisting of an anode and a cathode immersed in the wastewater will collect the harmful metal ions in a process known as electrolytic recovery.

The metal ions are attracted to the anode and can be collected and contained.

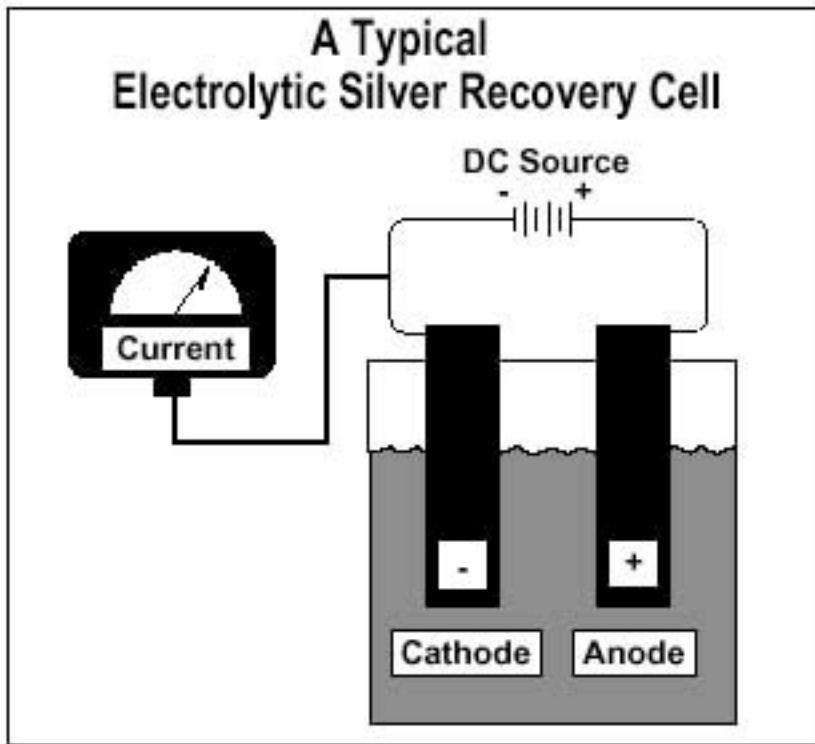

Wet Air Oxidation

In this hydrothermal treatment, compressed air is injected into a super-heated (175-325 °C), pressurized system to oxidize organic contaminants in wastewater.

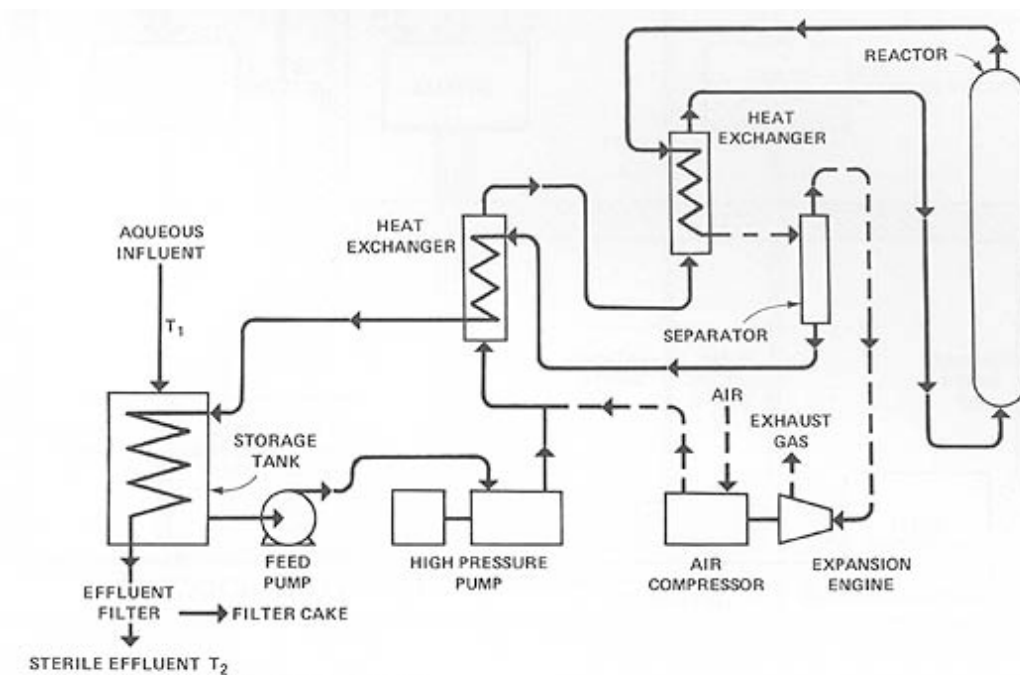

Figure 5-14.— Continuous wet oxidation process.

Biological Treatment

Microorganism's cellular functions utilize organic material as a source of carbon for cell growth and energy. Additionally, photosynthetic microorganisms use carbon dioxide as their source of carbon, oxidizing mineral compounds as a source of energy. These biological processes can be harnessed to treat wastewater streams containing organic wastes and mineral wastes.

Applications of hazardous waste management technologies to brownfield remediation:

Brownfield contamination usually impacts the soil and the groundwater of the site thus the aforementioned technologies and techniques have direct applications for the containment of chemical hazards.

Groundwater remediation:

When the contamination occurs in groundwater, there are the following technologies for containing the hazard:

Extraction and Treatment

With this method, contaminated groundwater is extracted and treated with appropriate treatment unit. Remediated water is pumped back into a stream and reinfiltated back into the water table. This technology works best for water soluble compounds; however, this is not suitable for free phase contaminants in permeable aquifers. The advantage of this method is that it is simple and effective; nevertheless, pumping could implicate large amounts of water

Biological barriers and filters

Having microbial organisms attach a liquid/liquid interface creates a biofilm that allows for the uptake and decomposition of contaminants. This can be used to treat hydrocarbons and other organic/aromatic compounds. The advantage is that biofilm technology can be performed on site. A drawback is that unfavorable biological activity can occur if specific reaction conditions are not upheld.

On site aeration

On site aeration uses the principle of stripping as air is injected below or above the water table to trap volatile organics. This treatment is inexpensive and effective on volatile compounds; however, it fails to break down the products and as the concentration of the volatile compounds in the groundwater decreases, the effectiveness of this treatment decreases.

Soil Remediation

When the contamination occurs in soil, there are the following technologies for containing the hazard:

Soil flushing

To flush the soil of soluble compounds, the operator floods the area with an appropriate solvent, i.e. acids, bases, surfactants, water, then collects and treats or reuses the elutriate. If this technique is successful, no additional treatment is needed. Soil flushing can be used in permeable soils, but is difficult in tight soils and can cause contamination to migrate to other areas or into groundwater if the system is not installed properly.

Solidification/stabilization

Following the principle of adding solids such as lime, kiln dust, or cement, solidification causes the hazardous material to become insoluble. This is suitable for inorganic compounds and low-level radioactive waste, but not effective for containing organic compounds. Lime, cement, and kiln dust are inexpensive, widely available, and accessible products. The reaction produces solids that have low leachability. The mixing can be difficult at times and the volume of material will expand with the addition of solidification/stabilization agents.

On site vitrification

On site vitrification is a thermal treatment that converts contaminated soils into glass or other crystalline materials. Large electrodes are inserted into soils, generating enough heat to pyrolyze the contaminants. This technique is suitable for organic compounds that fuse or vaporize and hazardous metals. Some benefits are that excavation is unnecessary and products have low leachability. The process is however energy intensive and requires specialized equipment and a highly trained crew to execute the technique.

Chemical degradation

A chemical reaction is utilized to degrade the hazardous materials to less toxic, more elemental compounds through oxidation, reduction, and other chemical reactions mentioned above. This technique is good for metals, chlorinated organics, pesticides, and general organic waste. The effectiveness of the reaction depends on soil type and type of waste. It is important to note that some breakdown products might be toxic and that some reagents are relatively expensive.

Biodegradation

Microbial organisms, using natural processes, convert waste to biomass and harmless by-products. Biodegradation is suitable for oils and other organics. The benefits are that biodegradation is highly effective, low cost, and no excavation of the site is necessary. The effectiveness of the treatment depends on ambient conditions, the nature of contamination, and the soil type. Unfortunately, some of the by-products may be harmful, soluble, or mobile, causing future problems if left unchecked.

Soil vapor extraction

Extraction of volatile organics with this technique occurs via a vacuum pump. Soil vapor extraction is ideal for highly volatile compounds and this technique provides permanent

remediation once material is extracted. The application of this technology is limited to permeable soils as the vapor must be able to move within the channels between soil particles.

Photolysis

Photolysis is the breakdown of compounds with light energy such as ultraviolet light. Although field data of the expected breakdown of contaminants is still not extensive, this technology requires no excavation and is suitable for PCBs, dioxin, formaldehyde, along with other specific organic compounds.

On site incineration

Using an onsite kiln incinerator, contaminated soils are burned. This is effective in treating PCBs, volatile, and semi-volatile compounds. Incineration boasts high treatment efficiencies; however, it is rather expensive, energy intensive, and can cause severe local air pollution problems. Additionally, the site must be excavated, but the hot combustion gases from the incineration can be passed through a boiler and turbine generator to recuperate energy.

Each of these technologies and treatment techniques has specific applications for certain contaminations and site properties. It is therefore essential that before any containment plan is carried out, there must be extensive research as to the nature of the contamination and the properties of the brownfield site in question.

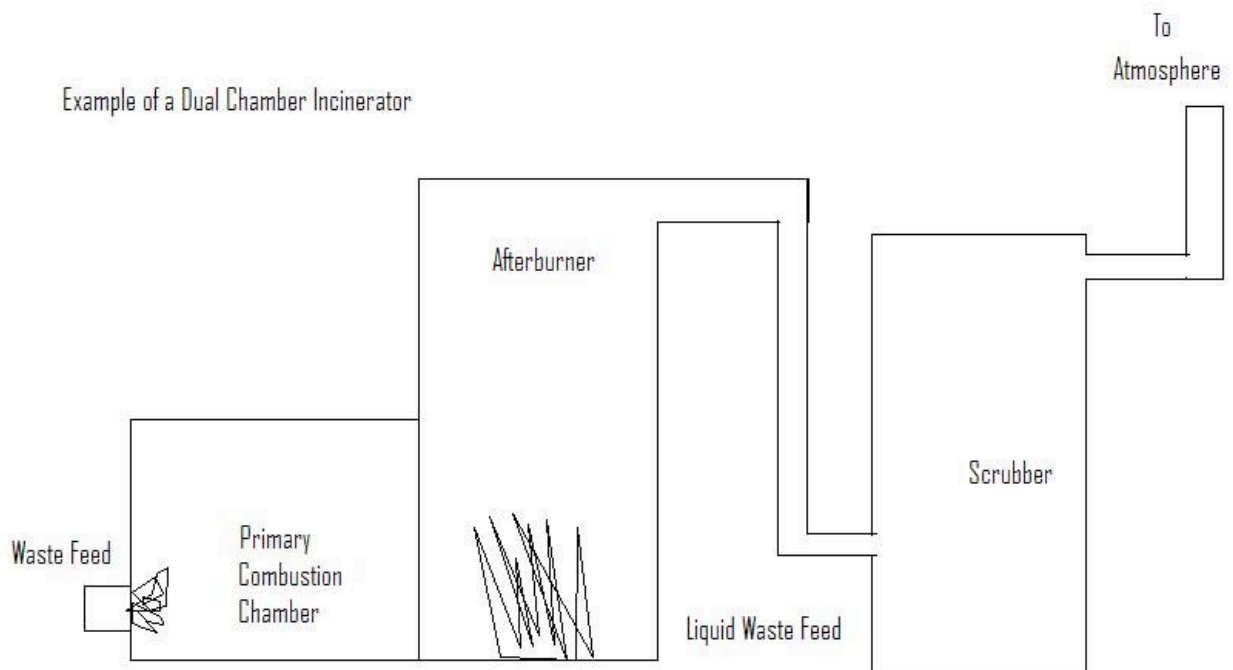

VII. Brownfields in Delaware County

A. Superfunds

Austin Avenue Radiation

133 Austin Ave, Lansdowne, PA

Contacts:

Remedial Project Manager: David Turner
215-814-3216
turner.david@epa.gov

Community Involvement Coordinator: Carrie Deitzel
215-814-5525
1-800-553-2509
deitzel.carrie@epa.gov

Governmental Liaison: Megan Mackey
215-814-5534
mackey.megan@epa.gov



Figure 6: Source: Environmental Protection Administration

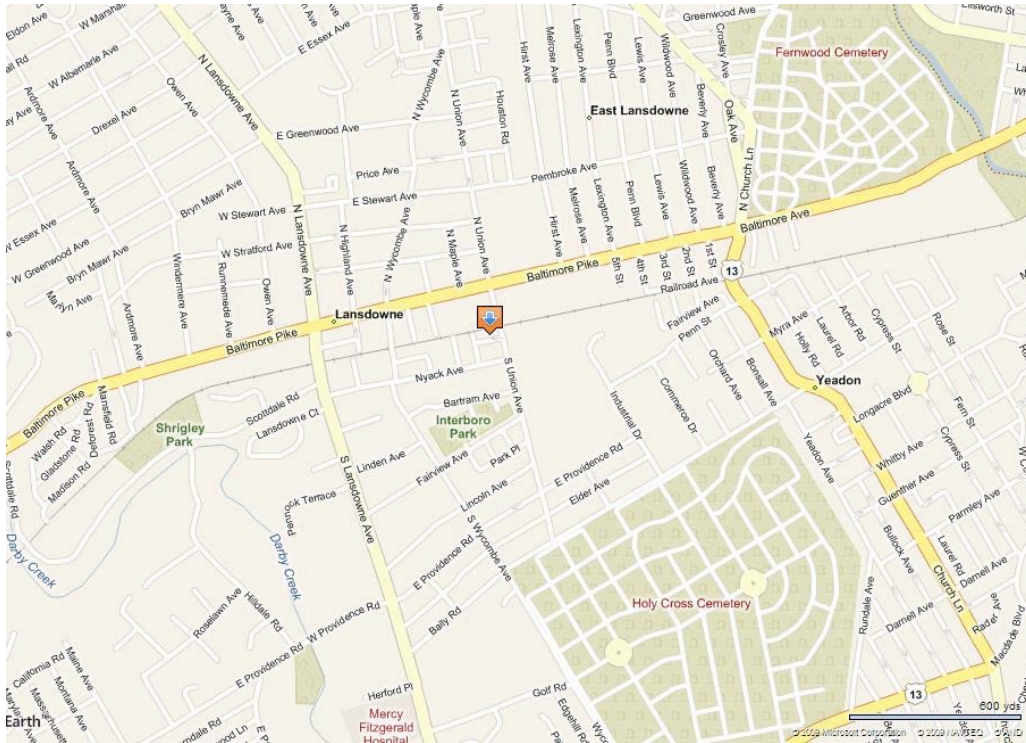

Figure 7: (Source: Microsoft Virtual Earth)

Responsible government offices: The EPA has been involved with this site in its entirety.

Site description:

History: This is Lansdowne’s second Superfund site. The first, which belonged to a scientist who worked with radioactive materials in his basement, is indirectly linked to this second one. The Austin Avenue Radiation site consists of 40 properties located in Lansdowne Borough, East Lansdowne Borough, Upper Darby Township, Aldan Borough, Yeadon Borough, and Darby Borough, Pennsylvania. Contamination of these properties resulted from the disposal of radioactive materials generated by W. L. Cummings Radium Processing Co. This company conducted radium refining operations from 1915 to 1925. Radium tailings resulting from these plant operations were mixed with materials used to construct buildings or used for fill material at the various properties in Delaware County.

There were three other such refineries in the U.S. at that time—all four became Superfund sites. This refinery created hundreds of tons of radioactive sand as a byproduct of its operations. This Superfund site is unique in that it is not just one site, but in fact includes 22 homes and 40 properties spread out across a two mile radius. However, the site originated at 133 Austin Ave. The site was delisted from the national priorities list in 2001 and a five year review has concluded that remediation has been successful.

Nature of the contamination: This refinery created hundreds of tons of radioactive sand as a byproduct of its operations. In 1991, this sand was found to be heavily

contaminating the adjacent 133 Austin Ave Site. The 133 Austin Ave. site was added to the Superfund national priorities list in 1992. However, there was still 500 tons of radioactive sand unaccounted for. In 1996, the EPA decided to bring in a radiation detecting van, and found that at least 200 tons of this radioactive sand was used in the construction of over 21 homes in Lansdowne and neighboring towns. Superfund status was extended to these homes in order to facilitate demolition and relocation of residents. Superfund status was also extended to the warehouse directly adjacent to the 133 Austin Ave Site.



The map above of eastern Delaware County outlines the two-mile radius where EPA's scanner van was deployed for radium.

Figure 8: Map of the two mile radius where the EPA's scanner van was deployed (Original Source: SEPTA 1990)

Past and current remediation and development efforts: In June 1994, following a comprehensive site investigation, the EPA selected a remedy to clean up the site. The remedy included the removal of materials contaminated with radioactive waste, the demolition of contaminated houses, the repairing of one contaminated house, the permanent relocation of residents of eight of the demolished houses, the rebuilding of ten of the houses, and the removal of contaminated soils on 21 different properties in five municipalities.

Under an Interagency Agreement with the EPA, the U.S. Army Corp of Engineers cooperated on the design phase for the remedy selected in 1994. Site cleanup activities began in late 1995 and were completed in November 1997. All the permanent residential relocations have been completed. All radiologically contaminated structures have been dismantled, and the associated contaminated soils on the affected properties have been excavated and shipped off site for disposal. Excavation of the warehouse property, the most heavily contaminated property, began in April 1997 and was completed in November 1997. EPA and USACE transferred ownership of the warehouse property back to its owner. By February 1998, all 11 home rebuilds were completed, and the properties were returned to their respective owners. Some properties were not rebuilt, because the home owners chose to be permanently relocated. These properties have been transferred as vacant lots to the local municipalities in which they lie, as requested by the municipalities which agreed to assume ownership and to use the properties for the benefit of the communities.

In September, 1996, EPA issued a No Action Record of Decision for groundwater at the site. The total amount of radiologically contaminated materials disposed off site was 241 rail cars (approximately 20,000 tons). A five-year review was completed and demonstrates that the cleanup has been effective.

Plans for the future (remediation, development, use): remediation is complete. There are no known future plans for further remediation.

Past and present legal actions: no legal actions were found to have taken place.

East Tenth St.

201 E. 10th St, Marcus Hook

Photos:

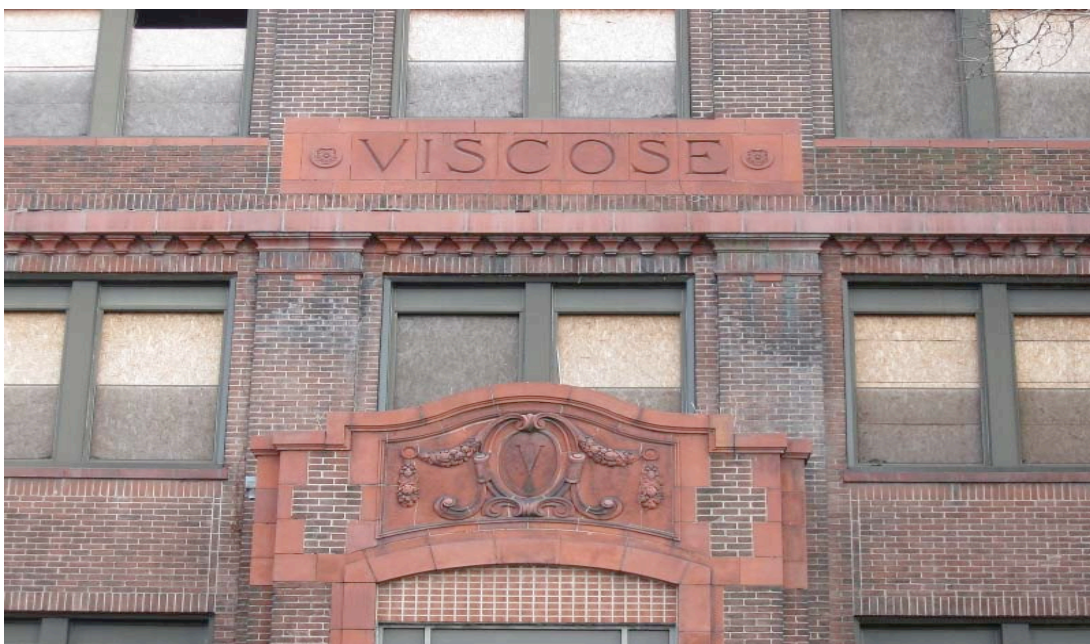

Map (Source: Google Maps):

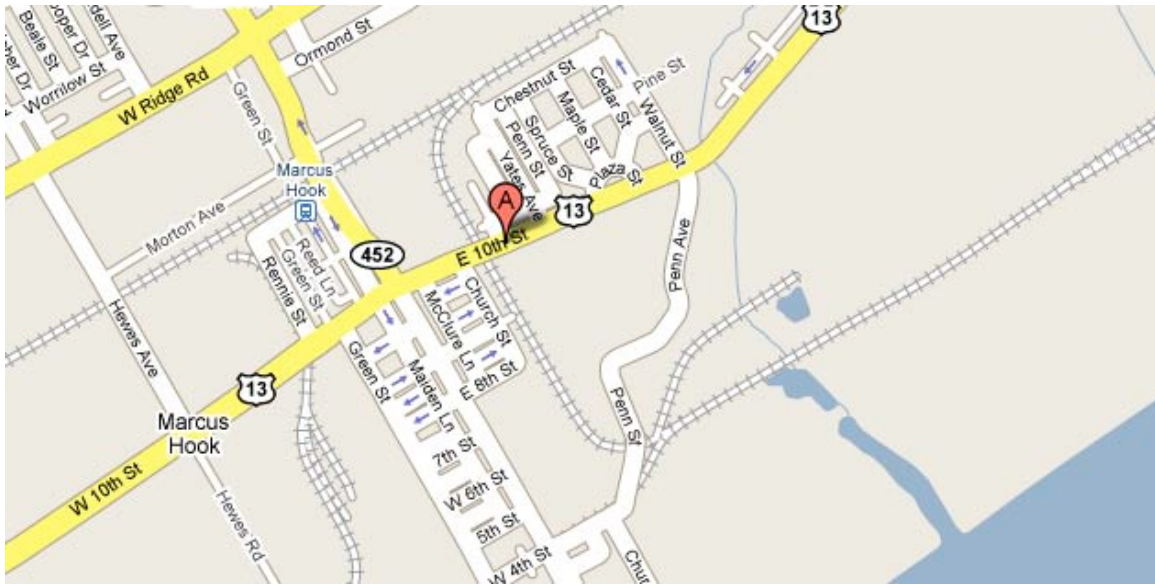

Responsible government offices:

EPA was involved for awhile but now the responsibility lies with the Department of Environmental Protection HSCA

Site Description:

History: The 36 acre parcel of land was purchased in 1910 to become the first manufacturer of rayon in the US. In 1958 the production of cellophane replaced rayon and then in 1963 FMC Corp purchased the site. The operated the plant until 1977 and then Marcus Hook Business Commerce Center obtained the property in 1986. The property was sold and leased in 23 individual plots. The DEP was aware of the site and had performed environmental assessment acts since 1979 but in 1990 they found an underground tunnel containing a deadly concoction of organic compounds and metals as well as leaking transformers and asbestos on site. In 1994 the site was recommended for the National Priorities List (Superfund) however in the end Pennsylvania did not agree to the nomination to the list and decided to manage the cleanup under the state Land Recycling Act.

Nature of the contamination: The contamination list is quite dire:

- Groundwater: volatile organic compounds (VOC), chemical components of solvents and degreasers, inorganic contaminants
- Soil: PCB's, asbestos, heavy metal, other organic contaminants; there is a sludge filled tunnel located on one of the lots contaminated with chloroform, cadmium, and mercury;
- Surface water: sediments in adjacent Marcus Hook Creek—designated by the state for protection of aquatic life—are contaminated with PCB's.

Past and current remediation and development efforts: Parties potentially responsible for contamination removed asbestos, old transformers, & PCB-contaminated cement from several buildings. They also constructed fences and funded site assessments.

Plans for the future (remediation, development, use): Cleanup the sludge tunnel and remaining contaminants as well as continuous monitoring of groundwater and soil.

Past and present legal actions: FMC agreed to cleanup as outlined in the DEP environmental assessment.

Havertown PCP

Eagle Road RC Drawer F
Haverford, Pennsylvania, 19041

Contact:
Remedial Project Manager: Jill Lowe
215-814-3123
lowe.jill@epa.gov

Map:

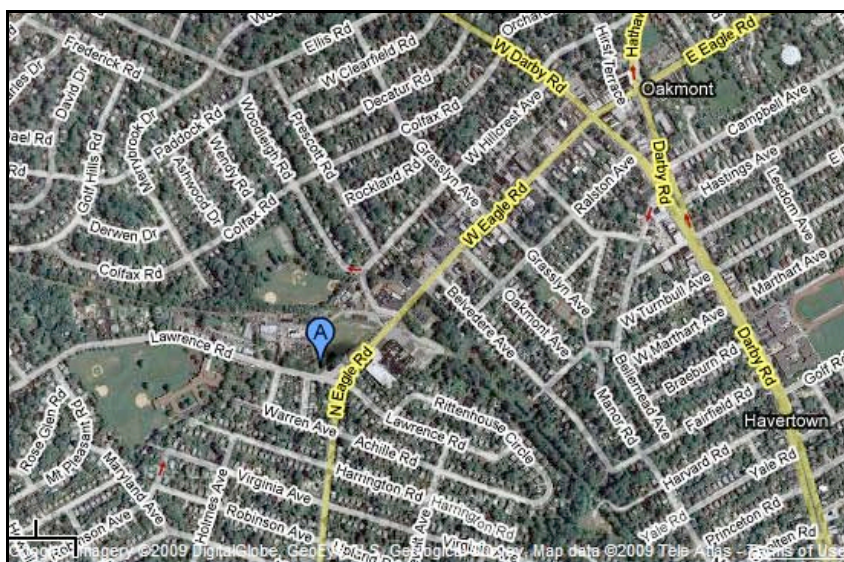

Figure 9: Havertown PCP site (Source: Google Maps)

Responsible government offices:

The EPA is the lead government office because it is designated as a superfund site. Additionally, there are *potentially responsible parties* whom the EPA is trying to involve in the cleanup process.

Site Description:

History: From 1947 to 1991, Natural Wood Preservers used the site as a wood treatment plant. Hazardous chemicals including gasoline, dioxins, and pentachlorophenol (PCP), were used and created as waste products in the treatment process. The company dumped waste directly into an on-site well. The chemicals were transported by water into Naylor's creek, which is a tributary of the Delaware River.

Nature of the contamination: There are numerous contaminants in the air, water, and soil at the site. Some of the most prevalent are various chlorophenol groups as the PCP degrades. There are many possible sources for the contaminants including glues, paints, gasoline, and other substances used in industrial processes. Most are not carcinogenic but still have negative health effects on individuals who are exposed to the contaminants for long periods of time or in high concentrations. For a complete list of contaminants see the online reference listed below.

Past and current remediation and development efforts:

Past

1984: A short term cleanup by Natural Wood Preservers

1990: Removal

1990-1991: Disposal offsite; Oil Water Separation; Pump And Treat; Recovery Wells; Subsurface Drain; and Surface Drainage Control.

1994: Removal

1997: Five Year Review

2000: Five Year Review and Removal

2003: Pump And Treat; Recovery Wells; and Subsurface Drain.

2005: Five Year Review and Removal

Current

2008: The EPA website lists that current remedial action that started September 10th is still underway. The specifics of remediation efforts are not listed. However, details of some recent remediation actions are listed as:

- Four recovery wells
- One collection trench
- A pre-treatment system to break-oil-water emulsion, remove metals, and remove suspended solids in extracted ground water

- Aboveground system employing three 30-kW ultraviolet/oxidation (UV/OX) lamps, a peroxide destruction unit, and two granular activated carbon units to collectively destroy or remove organic contaminants

Plans for the future (remediation, development, use): Currently, there are no clear plans for redevelopment, although continued remediation action and site monitoring is underway. The Haverford PCP site is located across the street from a former bubble gum factory. Haverford officials have expressed interest in redeveloping the land where the former chewing gum factory is located. However, the current owners are asking for \$6 million, which is more than the township wants to pay. Township officials are considering the option of invoking eminent domain to acquire the property that was used by the Philadelphia Chewing Gum Company. Proposed replacements for the factory include a police station, library or recreation center. There are concerns that remaining groundwater contamination spread from the Haverford PCP site could continue to cause problems on the former gum factory property in the future.

Past and present legal actions: Both local and federal government offices tried to force Natural Wood Preservers to stop dumping. In 1973, state authorities pursued legal procedures that would require Natural Wood Preservers and surrounding private companies to clean up the contaminated area. The litigation ended after 7 years with a ruling that required the company to clean up the site.

Even before litigation ended, the Environmental Protection Agency stepped in with emergency action. Wells were drilled allowing the PCP to be pumped to the surface for treatment. The owners did not want to cooperate with the EPA at that time, which led to its addition onto the National Priorities List for cleanup. By 1991, Natural Wood Preservers no longer retained ownership of the site. As a result, the site was given to state and federal agencies for cleanup. Nevertheless, according to the EPA's most recent report on the site, the agency is trying to get potentially responsible parties involved with remediation efforts.

Terminology

Potentially Responsible Party (PRP): Any individual or company--including owners, operators, transporters or generators--potentially responsible for, or contributing to a spill or other contamination at a Superfund site. Whenever possible, through administrative and legal actions, EPA requires PRPs to clean up hazardous sites they have contaminated.

Removal: A removal is a short-term cleanup intended to stabilize or clean up a site that poses an imminent and substantial threat to human health or the environment. Removals can occur at any stage of the Superfund cleanup process, but are often the first response upon discovery of a hazardous substance at a site.

Hilltop Residential Lab

EPA ID# PASFN0305565
7110 Hill Top
Upper Darby, PA 19082
Delaware County

Map/Photo:

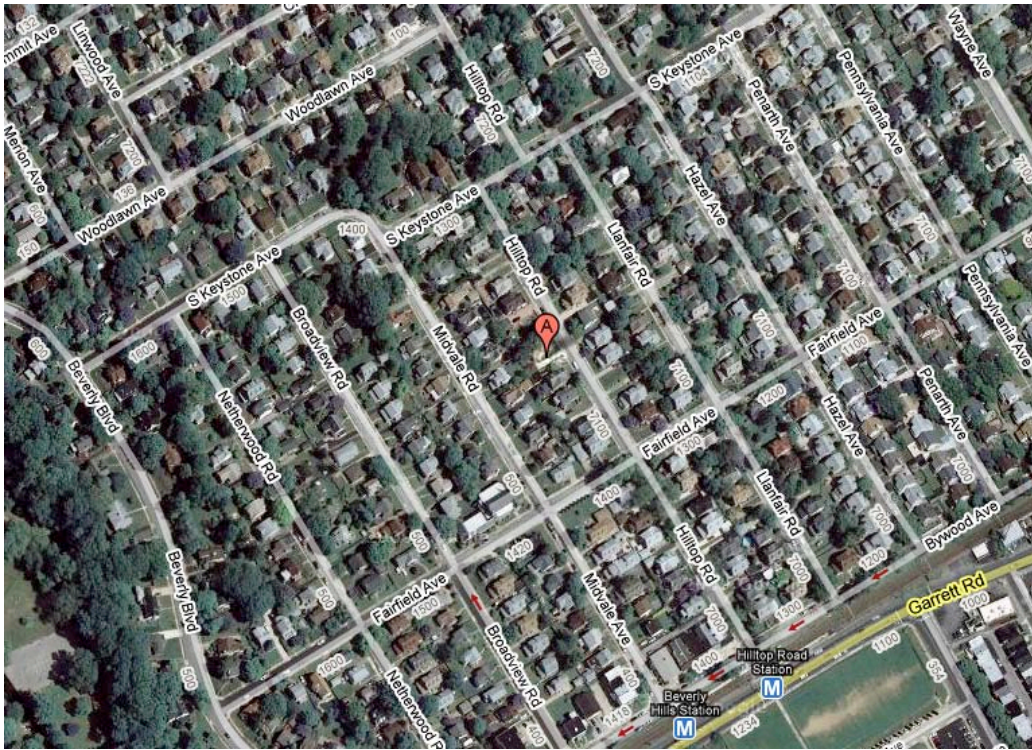

Figure 10: Hilltop Residential Lab site (Source: Google Maps)

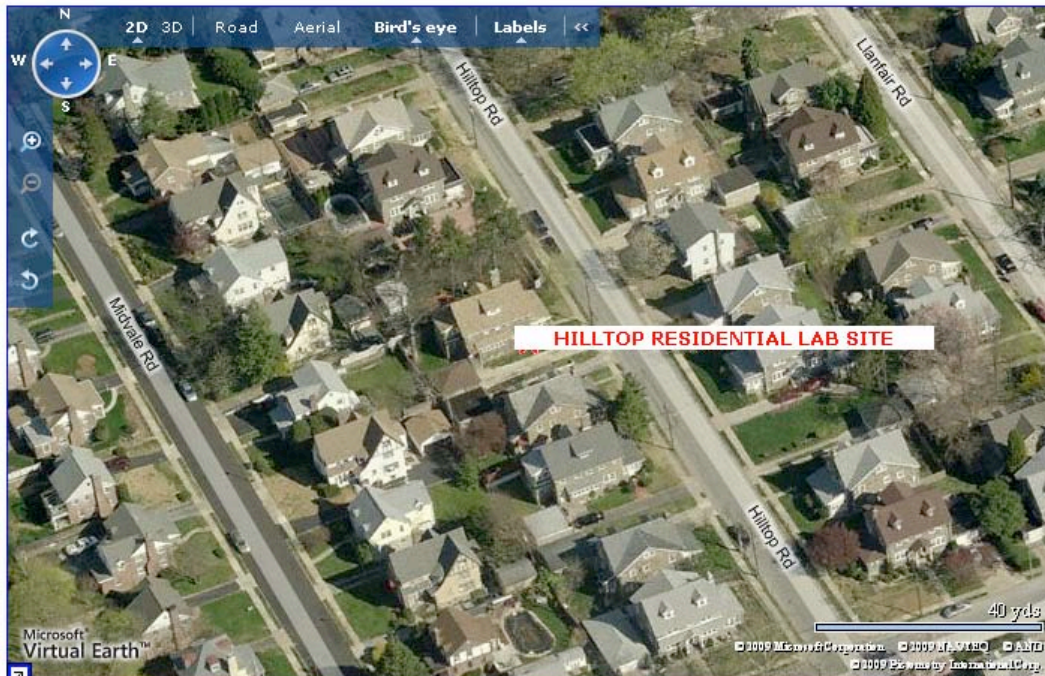

Figure 11: View of Hilltop Residential Lab (Source: EPA Faculty Location Information, http://oaspub.epa.gov/enviro/lrt_viewer.map_page?sys_acrnm=CERCLIS&sys_id=PASFN0305565)

Responsible government offices:

U.S. Environmental Protection Agency (EPA), Region 3:

1650 Arch Street

Philadelphia, PA 19103-2029

On-Scene Coordinator (OSC): Kevin Boyd

Community Involvement Section: Hal Yates

Community Involvement Coordinator: Bill Hudson (Hudson.William@epa.gov)

U.S. Drug Enforcement Administration (DEA): Patrick Trainor

Delaware County Emergency Services: Ed Truitt

Upper Darby Police: Captain Rudy D'Alesio, Julie Slothower

SATA

ERRS

Site Description:

History: The site is a single family home in a residential area, with a middle school two blocks away. On March 14, 2000, the EPA OSC responded to a statement that there were chemicals in the basement of the house. After being granted access to the house, drums of chemicals that were thought to be fire or explosion hazards were found and put in the backyard of the house for inventory and removal. Roughly a week later the chemical was found to be chloral hydrate, and later that week the drums were removed from the site for disposal.

Nature of the contamination: Chloral hydrate (sedative-hypnotic).

Past and current remediation and development efforts: Removal and disposal of chemicals completed.

Plans for the future (remediation, development, use): No information.

Past and present legal actions: No information.

Lower Darby Creek Area

Darby Creek, between Cobbs Creek and the Delaware River

Darby Township, PA, 19023

Clearview Landfill: 84th Street and Lindbergh Boulevard

Folcroft Landfill: west side of Darby Creek (John Heinz National Wildlife Refuge)

Map:

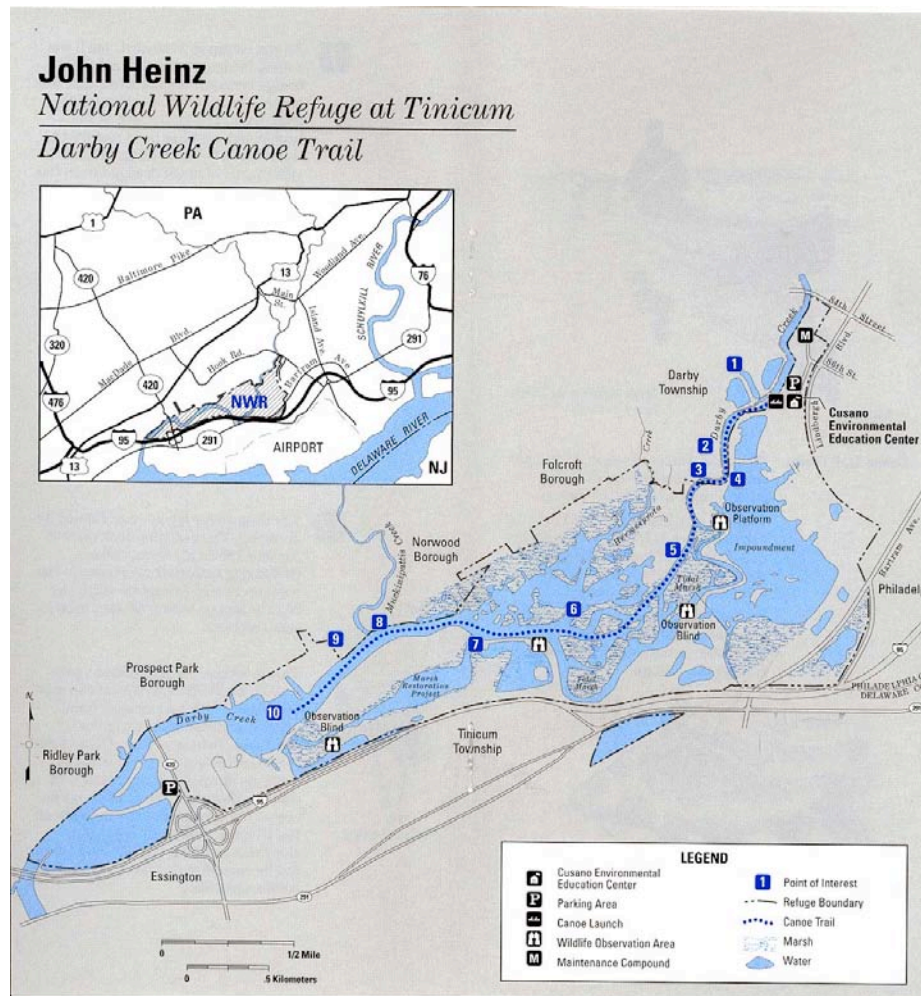

Figure 12: Map of John Heinz National Wildlife Refuge (Source: <http://www.fws.gov/northeast/heinz/DC%20Canoe%20Map1.jpg>)

Responsible government offices:

EPA

John Heinz National Wildlife Refuge (owned by US Fish and Wildlife Service)

Site Description:

History: The Lower Darby Creek Area Superfund site consists of two main sites, the Clearview and Folcroft Landfills. Several other smaller properties are adjacent to these landfills but have not been included under the Superfund site; these properties include the Sunoco Darby Creek tank farm, the former Delaware County sewage treatment plant, and the former Delaware County incinerator. Municipal wastes from Philadelphia and Delaware Counties were disposed of in the Clearview Landfill, which was as large as 65 acres when it was in use. The landfill was in operation without a permit from the 1950s to 1973, when it was closed by the Pennsylvania Department of Environmental Resources. The Folcroft Landfill was permitted to receive municipal, demolition, and hospital wastes from 1959 to 1974, but was likely receiving wastes as early as 1953. By 1971, the landfill had reached a size of 47.5 acres. The Folcroft Landfill was closed in 1974 because of permit infringements and unsuitable management. A fire burned eleven acres of the landfill in 1983, during which large amounts of illegally dumped hospital wastes were discovered. In 2001, the Lower Darby Creek was added to the National Priorities List under the Superfund program.

Nature of the contamination: The landfills were covered when they were closed in the 1970s, but later the covers were found to be eroding. The landfills release hazardous substances into Darby Creek. Contaminants include heavy metals, polycyclic aromatic hydrocarbons, volatile organic compounds, and polychlorinated biphenyls. These compounds may threaten the health of those who consume fish from Darby Creek, and also threaten the ecological health of the stream and nearby wetland environments.

Past and current remediation and development efforts: In 1976, the Clearview Landfill was bought by the Philadelphia Redevelopment Authority, which covered the landfill and constructed a residential development around the landfill's borders. The EPA sampled soils and wastes in 1998 as part of a comprehensive sampling project at Darby Creek. The EPA is currently performing a Remedial Investigation and Feasibility Study at the Clearview Landfill, which was begun in 2006. This involves soil, groundwater, stream water, and air sampling to assess the spread and nature of contamination, a human health assessment, and an ecological assessment. The Pennsylvania Department of Environmental Resources began inspections of the Folcroft Landfill in the 1970s and found evidence of illegal dumping of industrial liquid and other wastes. A Remedial Investigation and Feasibility Study is also being conducted at the Folcroft Landfill, under the responsibility of the EPA and several potentially responsible parties. Groundwater wells have been installed to monitor groundwater contamination at both landfills.

Plans for the future (remediation, development, use): Future remediation and development plans will depend on the outcome of the Remedial Investigation and Feasibility Studies of the landfills. As yet, no specific plans are publicized.

Past and present legal actions: In 1970, the state of Pennsylvania filed an injunction against the Clearview Landfill for operating without a permit. Three years later, the Clearview Land Development Corporation, the owner of the landfill, was ordered to develop a closure plan. In 1980, a notice of violation was issued to Clearview Land Development by the Pennsylvania Department of Environmental Protection after an investigation discovered dumping and burning of wastes such as demolition wastes, tires, furniture, household appliances, lumber, rugs, and other unapproved items. A series of notices of violation were issued over the next few years when repeated violations occurred. A former employee of the landfill died of cancer in 1962, and his wife filed a claim in 1984, charging that toxic wastes at the landfill caused her husband's death. The employee's nephew, also a former employee, testified in the case. He stated that he had buried poisonous chemicals at the landfill, and was often ill after work. The owner of Clearview Land Development Corporation, Richard Heller, often called him at night to subdue fires to which local firefighters refused to respond. Illegal dumping is believed to have continued until at least 1998. EPA gained federal court-ordered access to the Clearview Landfill in 2005 after many legal negotiations.

In 1970, a notice of violation was issued to the owner of the Folcroft Landfill, Wilbur Henderson, for multiple instances of dumping industrial wastes without a permit. In 1980, the Department of the Interior bought the Folcroft Landfill to add to the John Heinz National Wildlife Refuge. The EPA was directed to work with the Fish and Wildlife Service to evaluate environmental and health threats and recommend remediation efforts. The EPA completed a legal agreement with a group of 14 potentially responsible parties that gives them the responsibility of working with the Fish and Wildlife Service to conduct a Remedial Investigation and Feasibility Study at the Folcroft Landfill.

Oil Tank Lines, Inc.

EPA ID# PA0001909522
2 Industrial Dr, Darby, PA 19023

Map/Photos:



Figure 13: Location of the Oil Tank Line site (Source: Google Maps)

Responsible government offices:

EPA – Mid-Atlantic Superfund
OSC: Robert F. Kelly (215-814-3268; kelly.robertj@epa.gov)

Site Description:

History: On April 23, 1997, the EPA and SATA responded to a fire at the Oil Tank Lines Site, where the building's contents were unknown. When access was granted to the

property two days later, 13 drum and tank samples were taken from outside of the building for testing, where 11 of the samples were found to be hazardous petroleum hydrocarbons. A notice of federal intent was issued based on the test results, and when the owners did not have the money to remove the chemicals, the U.S. Coast Guard was contacted for \$50,000 in aid. In late May of 1997, SATA and the EPA were called in to do emergency response containment action after a drum was found to be leaking. Full removal was completed, and assessed in June of 1997.

Nature of the contamination:

- Hazardous petroleum hydrocarbons stored on-site
- Underground storage tanks and other containers thought to be in poor condition
- Ground saturated with oil
- Upgradient of Darby Creek
- (For details on the specific contaminants, please refer to: http://oaspub.epa.gov/enviro/multisys2.get_list?facility_uin=110000338518)

Past and current remediation and development efforts: Full removal of chemicals stored in drums and other containers from site.

Plans for the future (remediation, development, use): No information.

Past and present legal actions: No information.

Pennsylvania Salt Service

Address: 601 Chester Pike, Ridley Park, PA

Contact: On-Scene Coordinator

Christopher Thomas

215-814-5555

thomas.christopher@epa.gov



Figure 14: Pennsylvania Salt Service (Source: Microsoft Virtual Earth)

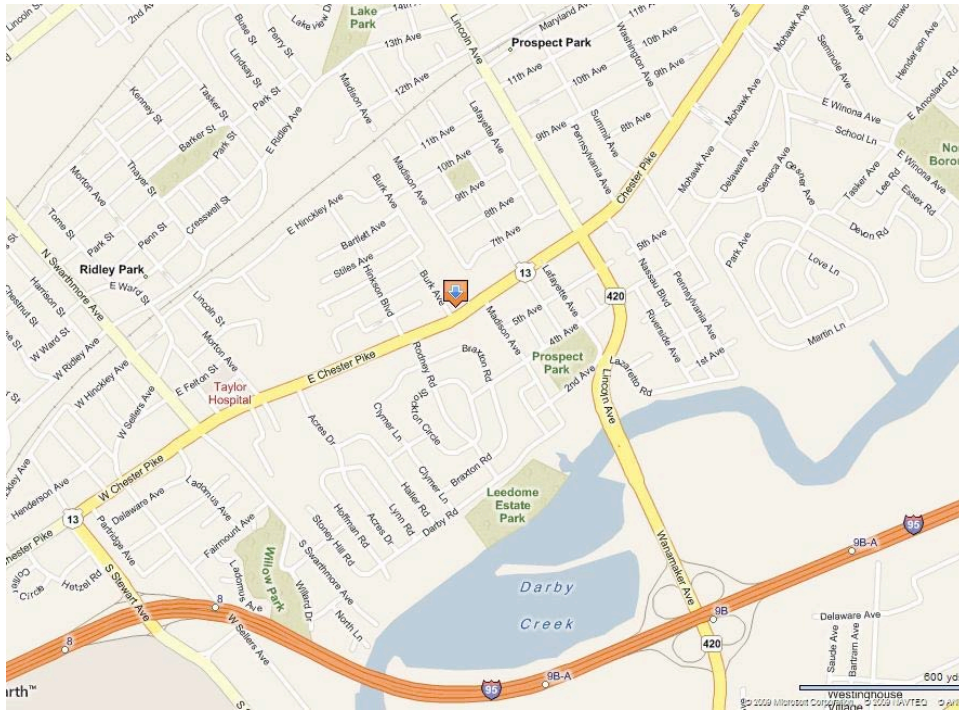

Figure 15: (Source: Microsoft Virtual Earth)

Responsible government offices:

The EPA was involved in the initial site remediation in 1993. The site has since been delisted from the national priorities list. Responsibility for the site now lies with PADEP and the Ridley Park municipal government.

Site Description:

History: This site was named a Superfund site after multiple 55 gallon drums were discovered inside of an unlocked warehouse onsite. The drums were stacked against the walls, with some drums outside in the open. Pools of standing liquid were found by the officer, whose department initiated a process to involve the EPA. A cleanup action was initiated in 1993 using CERCLA funding to seal and secure the site with the goal of mitigating immediate danger to the surrounding public. This site was of particular concern due to its close proximity to residences, a public park, a church, and railroad tracks, all of which were located within a one block radius.

Nature of the contamination: Multiple 55 gallon drums containing acetone, denatured alcohol, herbicides, flammable liquids, and other various strong acids and bases were found to be leaking at the site. There were thousands of these drums at the location, with the majority of those that had not begun to leak in a state of deteriorating condition. These drums were also not separated, and the combination of flammable liquids and other liquids presented a serious risk of creating a severe airborne toxin, if a fire were to occur. The drums were outside, in an unsecured location.

Past and current remediation and development efforts: A site cleanup was initiated jointly by the PADEP and EPA in 1993 using \$50,000 of CERCLA funding. The site was secured, deteriorated and/or leaking drums were placed into larger sealed drums, and drums were covered with protective material and separated to reduce the risk associated with mixing materials from the drums. The site owner was unable to pay for any remediation efforts. There are no current further remediation efforts, and all information seems to show that the site remains unchanged following the 1993 cleanup. No further actions have been taken.

Plans for the future (remediation, development, use): No known plans

Past and present legal actions: No legal actions were found.

Sackville Mills Property

Sackville Lane and Brookhaven Road
Nether Providence, PA 19086; Delaware County

Map:

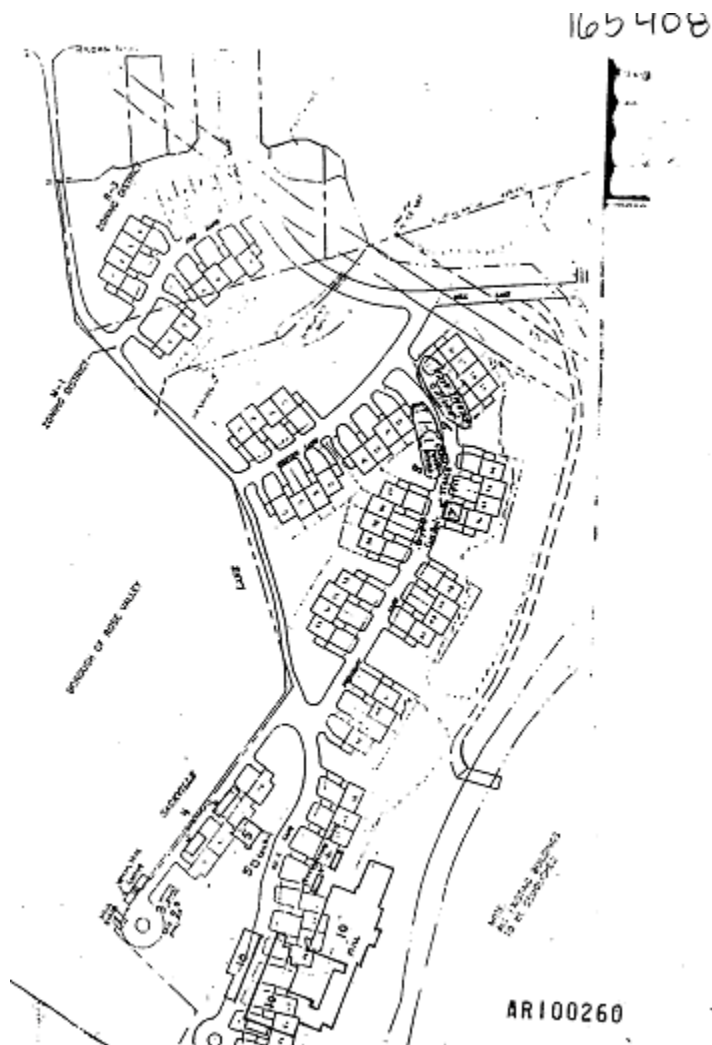

Source:

http://loggerhead.epa.gov/arweb/public/search_results.jsp?siteid=PA0000198846#

Responsible government offices:

EPA
Pennsylvania Department of Environmental Resources

Site Description:

History: The Sackville Mills operated for approximately 50 years until 1934, when it was closed because of an inspection by state medical authorities that revealed a possible contamination by anthrax bacteria, *Bacillus anthracis*. The Mills were in the business of making wool necktie linings. At the time of closure, the population of the small village around the Mills was ordered to be evacuated, and one death was caused by the infection. After the discovery of the germs, the approximately 300-person village of Sackville came out with shovels and rakes and cleaned up six truck loads of waste. In 1990 it was believed that there was no risk from Anthrax bacteria. In 1993, a fire incident revealed drums of unknown hazardous materials.

Nature of the contamination: Anthrax bacteria are suspected to have contaminated the soil and groundwater. Anthrax, a disease of sheep and cattle that causes pustules and swelling, can be transmitted to humans who have open cuts and work with wool or animal hides. The site consists of 42 acres, and Ridley Creek runs through the property. About 60 deteriorating containers of unknown, potentially toxic substances were discovered in 1994. Hazardous substances found include hydrochloric acid, acetic acid, sulfuric acid, perchloroethylene, polychlorinated biphenyls, and oils and greases. Reactive chemicals such as hydrogen peroxide were found close to combustible matter such as wood and oil, risking the ignition of a spontaneous fire. The EPA interviewed a former employee, who revealed that crates of animal hair potentially contaminated with anthrax bacteria had been buried at the site and may still prove dangerous.

Past and current remediation and development efforts: The EPA and state partners are currently performing site visits. The Pennsylvania Department of Environmental Resources conducted a site inspection in 1994. A CERCLA funding request was submitted in 1994 and was approved, and a Preliminary Assessment was performed in 1995 by the EPA.

Plans for the future (remediation, development, use): Once site visits are completed, a project manager will be assigned to the site to begin the remediation process. Development of a residential community once remediation is complete has been proposed. The plan is to build a residential development of approximately 80 townhouses known as Mills at Rose Valley.

Past and present legal actions: In 1987, the Sackville Mills Company agreed to a development proposal by Coslett Enterprises and Growth Properties (now known as Sackville Associates). As of 1994, this agreement has not yet come into effect. In 1994, the EPA informed the president of the Sackville Mills Company, Conrad Wolf, that the Mills were potentially liable under CERCLA and could be responsible for remediation due to public health threats at the site. This responsibility was officially assigned to Sackville Mills Company once the site was approved under CERCLA after the 1994 request.

Wade (ABM)

1 Flower Street, Chester, PA 19013

Photos:



Remediated CPA parking area on the Wade site.

Map:

South Chester Waterfront (detail),
Flower St. to Engle St.,
July 5, 1971



Image credit: pennpilot.psu.edu

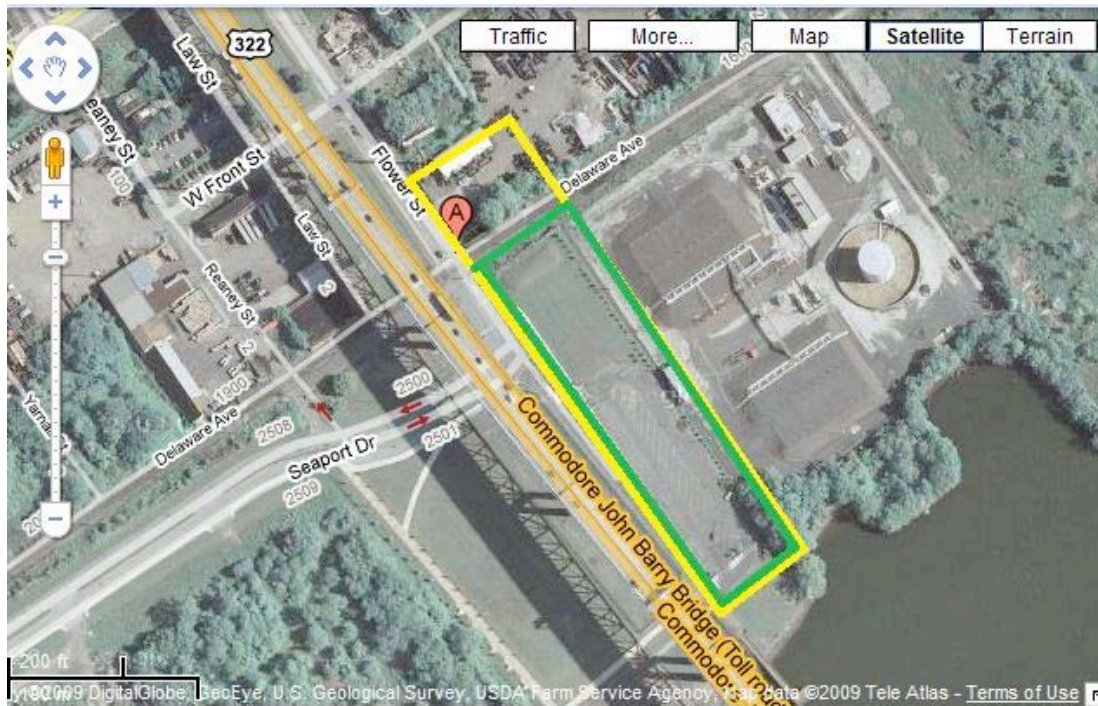

1 Flower Street; the yellow indicates the contaminated area and the green subset is the remediated parking lot.

Responsible government offices:

EPA:

Remedial Project Manager James J. Feeney (215) 814-3190

Community Involvement Coordinator David Polish (215) 814-3327

Site Description:

History: 1 Flower Street has a long history of industrial use. The three acre site lies on the west bank of the Delaware River in an ecologically sensitive region near wetlands. Once a textile mill, the site became a rubber reclaiming facility at the turn of the century. This once lucrative business ceased to be financially viable when local business man Melvin Wade became owner of the facility, thus he successfully augmented his income by accepting hazardous waste from waste disposal company ABM (also linked with the PECO/Chem Clear site), essentially turning his rubber reclaiming facility into a illegal toxic waste dump. This operation of illegal disposal and storage of extremely toxic waste carried on until a vicious and tragic fire scorched the site in 1978. In the aftermath of the fire, the EPA arrived on the site to take samples of soil and ground water. The preliminary assessment in 1979 declared the Wade dump site as a low priority. After a successive assessment in 1980, the site became a high priority at which point the EPA conducted extensive remediation, completed in 1989. The Chester Parking Authority currently owns the site, which is now a parking lot.

This table provides a summary of the industrial uses of 1 Flower Street and the owner at the time of the use:

Example: Industrial Activity at 1 Flower Street

| Date | Owner | Use |
|-------------|---|---|
| 1868-1905? | Auvergne Mills (N. Yarnall) | Manufacturing of Kentucky blue jeans, cotton and woolen goods |
| 1905-1916 | S. & L. Rubber Co. | Scrap rubber reclaiming |
| 1916-1959 | Bloomington Rubber Co. | Scrap rubber reclaiming |
| 1971-1975 | Eastern Rubber Reclaiming, Inc. (M. Wade) | Scrap rubber reclaiming |
| 1978 | ABM/Wade Fire | |
| 2003-2009 | Chester Parking Authority | Parking Lot |

Nature of the contamination: The Wade dump site is extremely contaminated with the presence of numerous toxic organic and inorganic compounds throughout the area in the ground, water, and buildings alike.

| Compound | Presence |
|----------------------------|---|
| ARSENIC | Buildings/Structures, Ground Water, Soil, Solid Waste |
| BENZENE | Buildings/Structures, Ground Water, Soil, Solid Waste |
| BIS(2-ETHYLHEXYL)PHTHALATE | Buildings/Structures, Ground Water, Soil, Solid Waste |
| CHLOROBENZENE | Ground Water Soil |
| CHLOROFORM | Buildings/Structures, Ground Water, Soil, Solid Waste |
| CHROMIUM (HEXAVALENT) | Buildings/Structures, Ground Water, Soil, Solid Waste |
| LEAD | Buildings/Structures Solid Waste |
| LEAD (INORGANIC) | Ground Water Soil |
| TETRACHLOROETHYLENE | Buildings/Structures, Ground Water, Soil, Solid Waste |
| TRICHLOROETHYLENE | Buildings/Structures, Ground Water, Soil, Solid Waste |

Past and current remediation and development efforts: Physical remediation has been completed on the site and it has been successfully remediated as a parking lot. EPA workers collected 5000 gallons of PCB contaminated waste and 10000 gallons of other hazardous waste for incineration. Additionally, they removed 155 tons of contaminated solids (soil, etc.). The final cleanup included: removing, decontaminating, and disposing of tires, tankers, waste piles, and buildings; contaminated soil removal; and site leveling, filling, and grading. The site was finally upgraded with an asphalt surface and an engineered storm water system.

Plans for the future (remediation, development, use): Completely remediated and continued use as parking lot owned and operated by the Chester Parking Authority.

Past and present legal actions: 01/31/1981 case vs. Melvin Wade to establish responsible party.

B. Resource Conservation and Recovery Act

Boeing Company, Ridley Park

CTR South
Stewart Ave & Industrial Hwy, Ridley Township

Map:

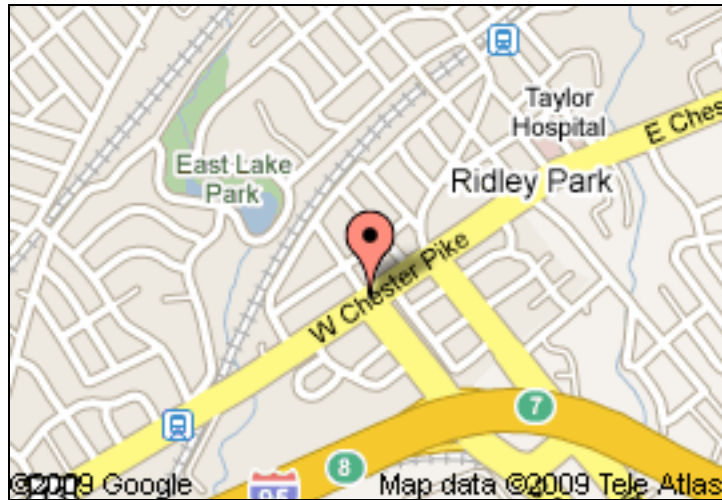

Figure 16: (Source: Google Maps)

Responsible government offices:

Pennsylvania Department of Environmental Protection (PADEP)
US Environmental Protection Agency (US EPA)

Site Description:

History: The site serves as an active aerospace manufacturing facility with approximately 3 million square feet of building space. Uses include aerospace manufacturing, maintenance, storage, laboratories, and support buildings relating to the production of commercial and military aircrafts.

Nature of the contamination: Metals from industrial manufacturing processes are the main contaminants listed in the *Waste & Recycling News* article.

Past and current remediation and development efforts: The site is currently considered to be sufficiently remediated. It appears that the Boeing Company still maintains ownership.

Plans for the future (remediation, development, use): No information could be found at this time.

Past and present legal actions: There are indications that the Boeing Company took preventative action by partnering with state and federal environmental agencies to undertake the first industrial cleanup in Pennsylvania as part of the One Cleanup Program. The agreement between state and federal agencies states that sites remediated under the state's brownfield program also satisfy three key federal laws: the Resource Conservation and Recovery Act; the Toxic Substances Control Act; and the Comprehensive Environmental Response Compensation Liability Act (CERCLA), which is also known as the Superfund law

BP Oil Refinery

Marcus Hook, PA

Photos:

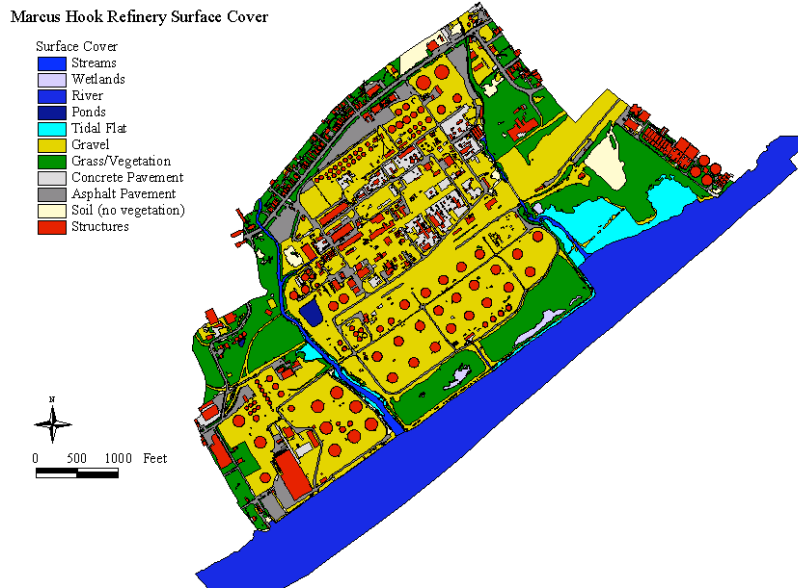

GIS Map of Marcus Hook Refinery Surface Cover (Source: Romanek Research Thesis)

Map:

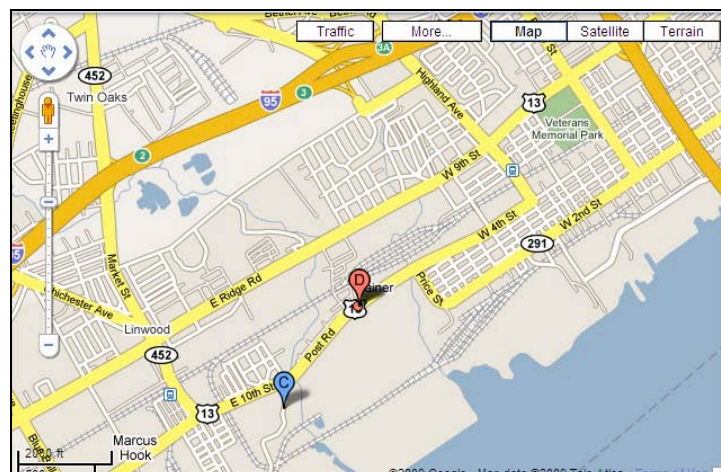

Figure 17: Google Map of TOSCO Refinery and Sunoco Refinery located on Delaware River waterfront

Responsible government offices: US EPA

Site Description:

History: On January 31, 1975, the (discrepancy in country of origin between 2 news articles, Greek or Liberian) *Corinthos* tanker, carrying hundreds of thousands of barrels of crude oil, collided with the ship the Edgar M. Queeny, which was carrying various chemicals (menthol, phenol, sturene, methanol, vinyl acetate, paraffin, possibly others). The collision occurred at the No.1 British Petroleum loading dock causing an oil spill into the Delaware River that lasted for several days (McDermott).

Nature of the contamination: Most of the contamination is caused by typical hazardous petroleum components such as benzene, toluene, ethyl benzene, total xylene, all of which are semi-volatile organic compounds, arsenic, chromium and lead.

Past and current remediation and development efforts:

- 1991-1996 BP Oil conducted clean-up activities at the Facility. Since 1991, the EPA and PADEP have been involved in evaluating the site's Solid Waste Management Units (SWMUs) and have identified 15 areas of concern.
- 1997: TOSCO purchased the facility and started operating it as Bayway Refinery. At that time, work related to the SWMUs and the areas of concern was completed except for the location of Lead Tank Bottom Pits.
- 2000: BP proposed to investigate and remediate the Facility under Pennsylvania's Land Recycling and Environmental Remediation Standards Act (Act 2) in 2000.
- 2008: BP remains involved in monitoring the site mainly through groundwater (supposedly through quarterly reports).

Plans for the future (remediation, development, use): No information could be found.

Congoleum

EPA ID #: PAD002343200
4401 Ridge Rd, Marcus Hook, PA 19061-5000

Satellite Map: Congoleum, north of the “A”

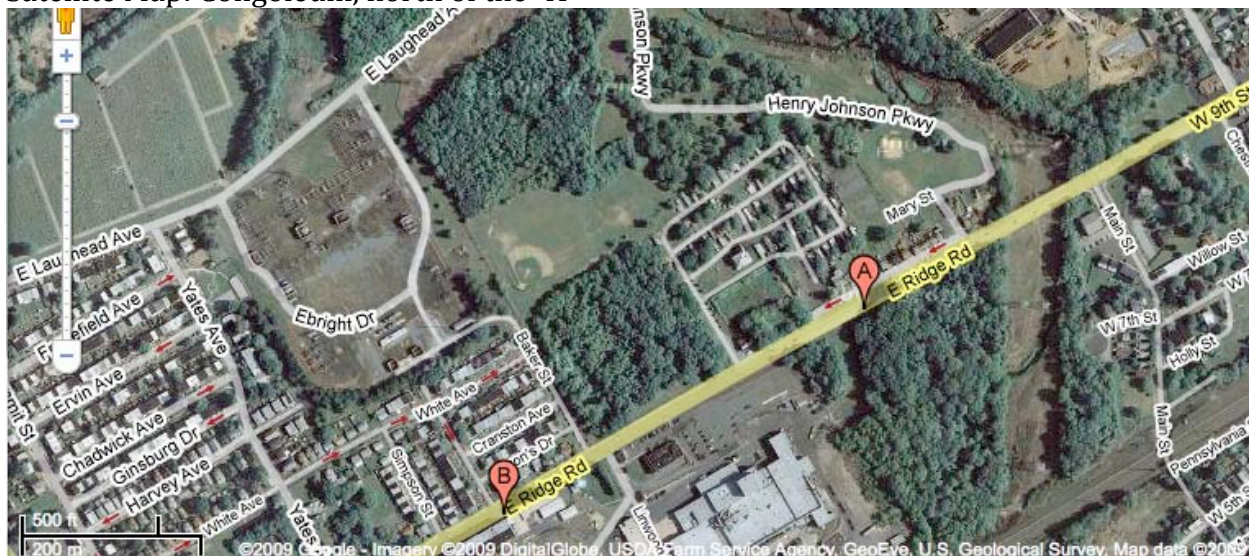

Courtesy Google Satellite Maps

Contact:

Khai M. Dao
U.S. Environmental Protection Agency – Region III
1650 Arch Street
Mailcode: 3WC22
Philadelphia, PA 19103
Phone: (215) 8142-5467
Email: dao.khai@epa.gov

Site Description :

History: Congoleum at Marcus Hook manufactures floor coverings. It is bordered on both sides of the facility by residences, business, and other manufacturers. In September 2003, the facility’s brownfield status came into question. The EPA, PA Department of Environmental Protection (PAEPA), and EPA’s contractor visited to see if the facility met the Environmental Indicators for Human Exposures and Migration of Contaminated Groundwater. Further testing was deemed necessary.

In 2004, the site was tested again, and elevated levels of heavy metals were found in the groundwater. Further testing is being conducted to determine whether the Congoleum plant is the source.

Nature of the contamination: Potential contamination of groundwater from heavy metals: chromium, lead and nickel.

Past and current remediation and development efforts: Currently, additional information and samples are being gathered by the EPA RCRA Corrective Action program.

Plans for the future (remediation, development, use): EPA will determine if corrective measures are needed if Congoleum is found to be the source of heavy metals in the surrounding groundwater.

East Coast Chemical Disposal Inc.

EPA ID #: PAD980706162
201 E Tenth St., Marcus Hook, PA 19061

Satellite Map: East Coast Chemical Disposal Inc., south of the "A."



Courtesy Google Satellite Maps

The facility borders directly on residences.

Contact:

EPA Project Manager
Mr. Griff Miller – 3LC30
U.S. Environmental Protection Agency – Region III
1650 Arch Street
Philadelphia, PA 19103-2029
Phone: (215) 814-3407
Email: miller.griff@epa.gov

Site Description:

History: This site was newly added to the RCRA Corrective Action Program. It will be evaluated by the EPA in conjunction with the state of Pennsylvania and managers from

Region 3, in which the facility is located. After the project manager visits, he or she will oversee corrective measures if problems arise affecting the environment and human health.

Nature of the contamination: To be determined.

Past and current remediation and development efforts: To be determined.

Plans for the future (remediation, development, use): To be determined.

Past and present legal actions: No information could be found.

General Chemical Corp.

EPA ID #: PAD990823742

6300 Philadelphia Pike, Marcus Hook, PA 19601

Satellite Map: General Chemical Corp sprawls over a large area, with offices situated at point "A."

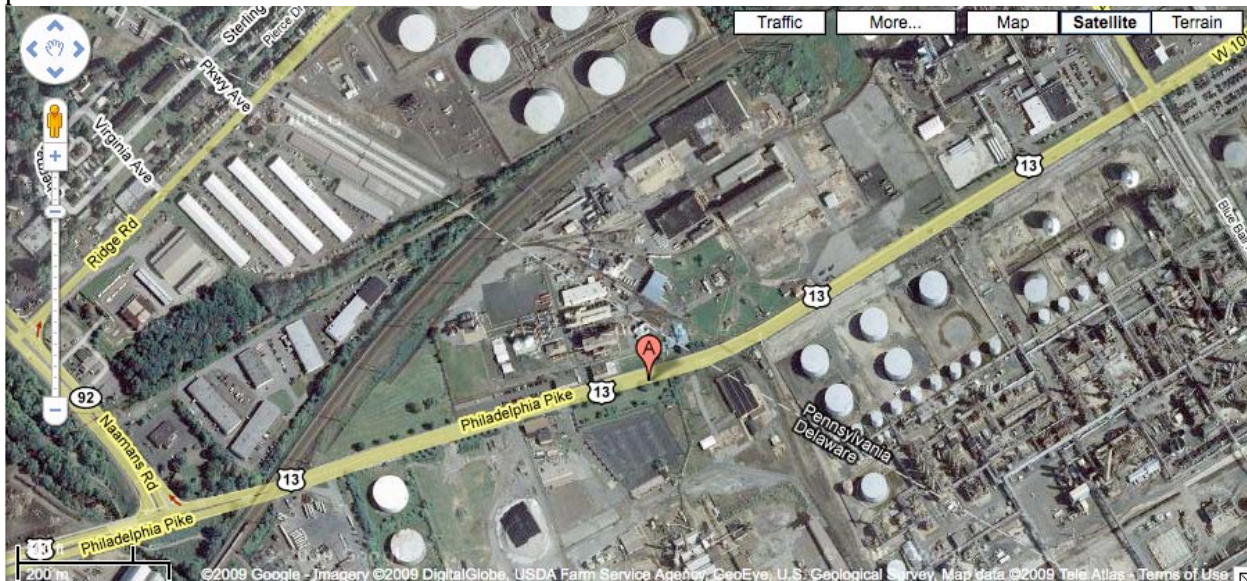

Courtesy of Google Satellite Maps

Contact:

EPA Project Manager
Mr. Russell Fish – 3LC20
U.S. Environmental Protection Agency – Region III
1650 Arch Street
Philadelphia, PA 19103-2029
Phone: (215) 814-3226
Email: fish.russell@epa.gov

Site Description:

History: Split into two sites, the former General Chemical facility (aka Delaware Valley Works ("DVW")) manufactured chemicals since the 1890's. General Chemical Corp. acquired the site from Allied Signal, a division of Honeywell, in 1986. Two-thirds of the DVW North Plant is located in PA with the remainder in Delaware. Virtually all of the DVW South Plant is located in Delaware. General Chemical and certain affiliates filed for bankruptcy in October 2003. After reorganization, General Chemical Corp. was found liable for cleaning up most of the soils in the DVW South Plant and Honeywell became liable for cleaning up the rest.

Nature of the contamination: Inorganic chemicals, pesticides, metals, volatile organic compounds in groundwater (see the EPA Progress Report for more detailed information).

Past and current remediation and development efforts:

- 2000: EPA issued Administrative Order requiring a facility-wide investigation and cleanup of Claymont, DE facility. Under the Resource Conservation and Recovery Act (RCRA), the requirements include: A) Stabilization of facility controlling human and ecological exposure, B) RCRA Facility Investigation to provide more information about Solid Waste Management Units, C) Corrective Measures Study to propose final cleanup actions as needed.
- Fall 2008: EPA collected sediment samples in Delaware River basin near facility. Data currently being evaluated.

Plans for the future (remediation, development, use): Site-specific testing continuing. Remediation plans will be constructed if necessary.

Past and present legal actions: To be determined.

Honeywell International, Inc.

EPA ID #: PAD981739758
(Honeywell-Delaware Valley Works (DVW); Formerly Allied Signal)
6300 Philadelphia Pike, Marcus Hook, PA 19601
(Also Claymont, DE 19703)

Map/Photo:

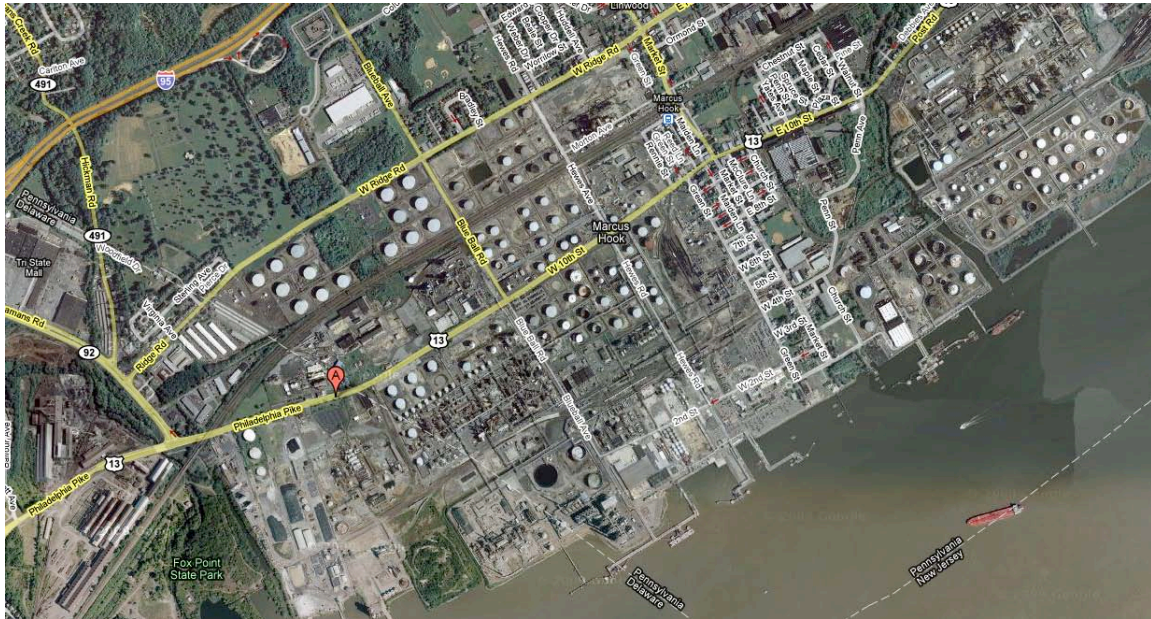

Figure 18: Honeywell International site (Source: Google Maps)

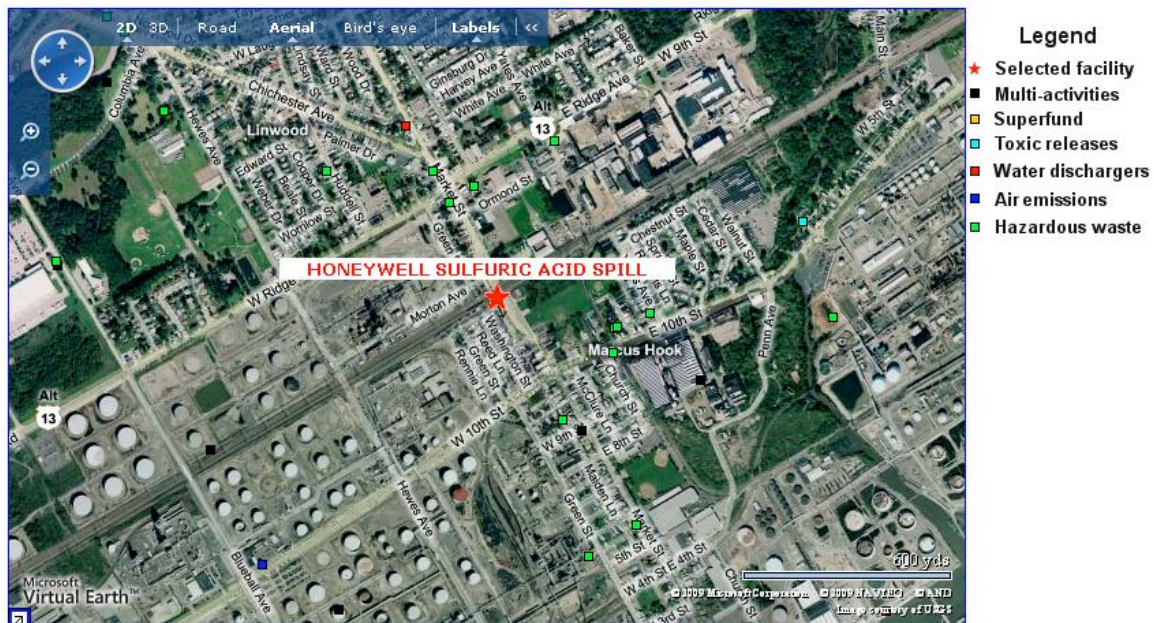

Figure 19: Location of Sulfuric Acid Spill and other Hazardous Waste sites (Source: EPA Facility Location Information, http://oaspub.epa.gov/enviro/lrt_viewer.map_page?sys_id=110017937410)

Responsible government offices:

EPA (Region 3)
EPA Project Manager: Russell Fish (215-814-3226; fish.russell@epa.gov)
Delaware Department of Natural Resources and Environmental Control

Site Description:

History: A chemical manufacturing plant, the DVW facility straddles the Pennsylvania and Delaware state lines in the towns of Claymont and Marcus Hook, respectively. Route 13 splits the facility, and the two sections on each side of the road are referred to as the DVW North Plant and South Plant. Both inorganic chemicals and pesticides have been products of manufacture since it began business in the late 1890s. General Chemicals Corporation (GCC) obtained the facility in 1986 from Allied Signal, which is now known as Honeywell International Inc. Allied Signal continued to own adjacent property where chemicals were and still are manufactured.

In October 2002, GCC filed for bankruptcy, and in October of 2003, were renewed under a Reorganization Plan, which delegated GCC the responsibility to undertake soil cleanups in the South Plant, while Honeywell was delegated to clean the rest of the facility.

Nature of the contamination:

- Metals and volatile organic compounds are main contaminants found in groundwater at the site.
- Sulfuric acid spill.

Past and current remediation and development efforts:

- 2003: Completed Phase I RCRA Facility Investigation (“RFI”)
 - Collection of groundwater and soil samples for testing, site wide groundwater testing
 - Additional investigation required based on sample results
- Fall/Winter 2004-2005: Completed Phase II RFI to collect additional data, as well as sediment samples from the Delaware River basin in areas adjacent to the Honeywell DVW.
- Currently under evaluation.

Plans for the future (remediation, development, use): Future remediation depends on the outcome of the test results.

Past and present legal actions: No information.

Marcus Hook Wastewater Treatment Facility MHPI

10th St.; Marcus Hook, PA 19061; Congressional District

Map:

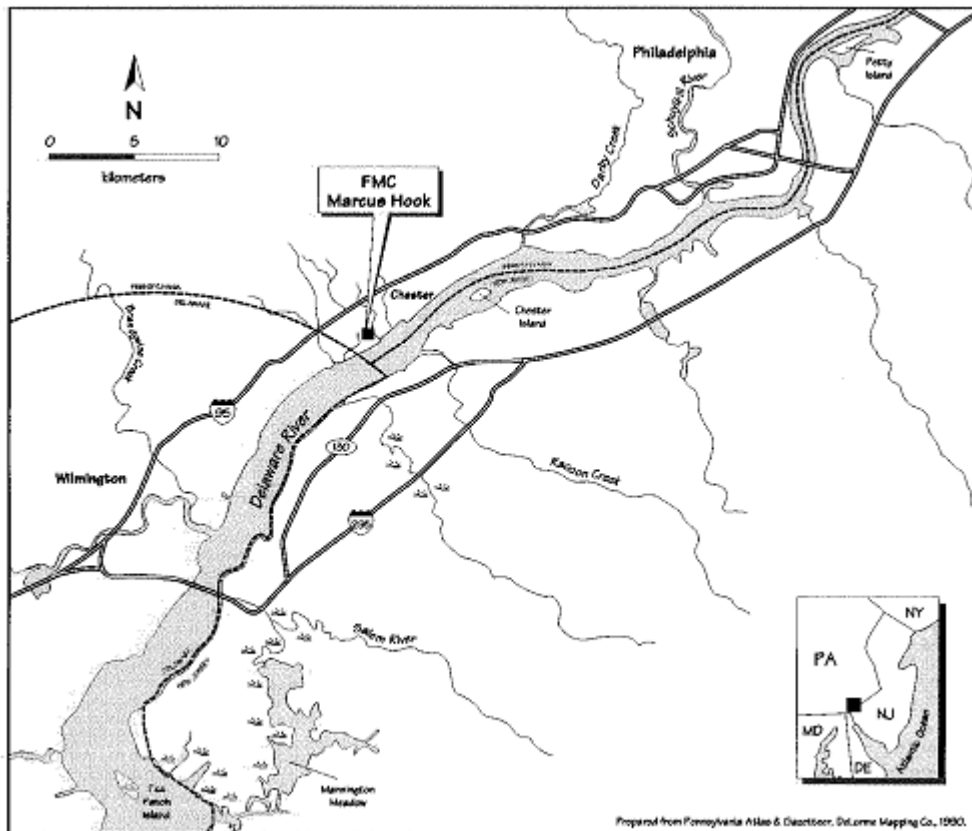

Source: On pages 2 and 3 of

http://response.restoration.noaa.gov/book_shelf/439_FMC_Marcus_Hook.pdf

Interactive map available at

http://oaspub.epa.gov/enviro/lrt_viewer.map_page?sys_acrnm=RCRAINFO&sys_id=PAD098160906

Responsible government offices:

EPA

Site Description:

History: This site is a recent addition to the Corrective Active Program of the Resource Conservation and Recovery Act of 1976, which controls disposal of solid and hazardous wastes. It is a 16-hectare site bordered by Marcus Hook Creek and close to the Delaware River. From the 1940s to 1954, American Viscose Corporation produced rayon at the site, and then transitioned to cellophane. American Viscose released acidic wastewater

and metal sulfides into Marcus Hook Creek until 1945, when the Sanitary Water Board directed them to build a wastewater treatment plant, which was subsequently built.

Nature of the contamination: The wastewater from the manufacturing facility contained sulfuric acid, zinc sulfate, sodium sulfate, lead and zinc sulfides, organic matter, and colloidal sulfur. Two unlined lagoons were used to store sludge waste, but it is unknown where the sludge from the lagoons was ultimately disposed of. K&S Processing operated an incinerator at the site that burned hospital waste; the ash was dumped on the bank of the Marcus Hook Creek until 1977. In 1991, a survey of the site discovered ground soil and sediment from Marcus Hook Creek to be contaminated by asbestos, PCBs, VOCs, SVOCs, and PAHs. Other contaminants found near the lagoon area included lead, zinc, and mercury.

Past and current remediation and development efforts: The EPA assessed the site in 1987 to evaluate hazardous waste release that may require corrective action. The site was identified for corrective action, but a cleanup solution has not been determined yet. The EPA has reported that there are no unacceptable human exposures to the contaminants and that contamination does not travel through the groundwater. The facility was covered with a 1-4 meter layer of soil and demolition debris (gravel, clay, brick, wood, concrete) in the early 1990s.

Plans for the future (remediation, development, use): No information is available.

Past and present legal actions: FMC Corporation (formerly Food Machinery Corporation and Food Machinery and Chemical Corporation) bought the manufacturing and wastewater treatment facility in 1963, and continued cellophane production. In 1986, Marcus Hook Business & Commerce Center bought the site, and K&S Processing purchased 1.2 hectares of the property. In 1991, the EPA and FMC agreed to perform a site assessment on a portion of the facility, not including the wastewater treatment plant or the incinerator.

PECO Energy Co., Chester Facility

1 EPA ID #: PAD000731026

Jeffrey Street and Delaware Avenue Chester, PA 19013, Congressional District

Photos:

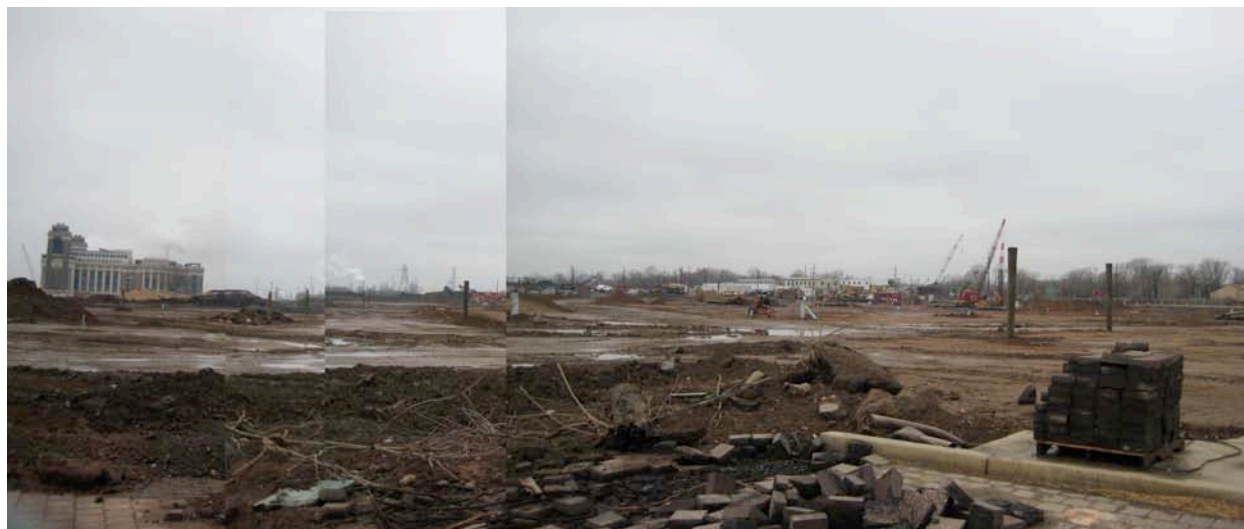

Responsible government offices:

Mr. Khai M. Dao
U.S. Environmental Protection Agency - Region III 1650 Arch Street
Mailcode: 3WC22 Philadelphia, PA 19103-2029
Phone: (215) 814-5467
Email: dao.khai@epa.gov

Ms. Sarah Pantelidou
Pennsylvania Department of Environmental Protection
2 East Main Street Norristown, PA 19401
Phone: (484) 250-5778
Email: spantelido@state.pa.us

Site Description:

History: This 90 acre site has been industrial since the 1800s and is part of the redevelopment plan for Chester's waterfront, including the stadium and mixed use commercial/residential development. On this site is the former coal fired power generating station, and at one point there was a resin manufacturing plant and hazardous waste recycler (linked with ABM chemical, responsible for Wade dump site). The site has changed hands many times but is now in the hands of the development company, Bucinni and Pollin, for mixed use development in conjunction with the soccer stadium.

Nature of the contamination: The soil contains tar and resin fragments that contain BTEX, PAH, and LNAPLs. The ground water contains BTEX, SVOCs, PAHs, and LNAPLs. Three areas on the site have groundwater runoff into the Delaware River, causing a hydrocarbon sheen and surface water contamination problems with BTEX and PAHs.

Past and current remediation and development efforts: In 2006, PECO remediated the site in compliance with the PADEP Act 2 and EPA Facility Lead Agreement. The cleanup activities consisted of excavation of impacted soil and groundwater remediation. PECO continues to operate and monitor the groundwater remediation under the post closure requirements.

Plans for the future (remediation, development, use): This land is part of the Chester Master Plan for redevelopment, including commercial and residential, and a soccer stadium. Current plans for remediation are unclear but lean towards more excavation and removal of contaminated soil.

Stoney Creek Technologies LLC

EPA ID #: PAD002330074
3300 W 4th St. Trainer, PA 19061 Congressional District

Photos:



Map:

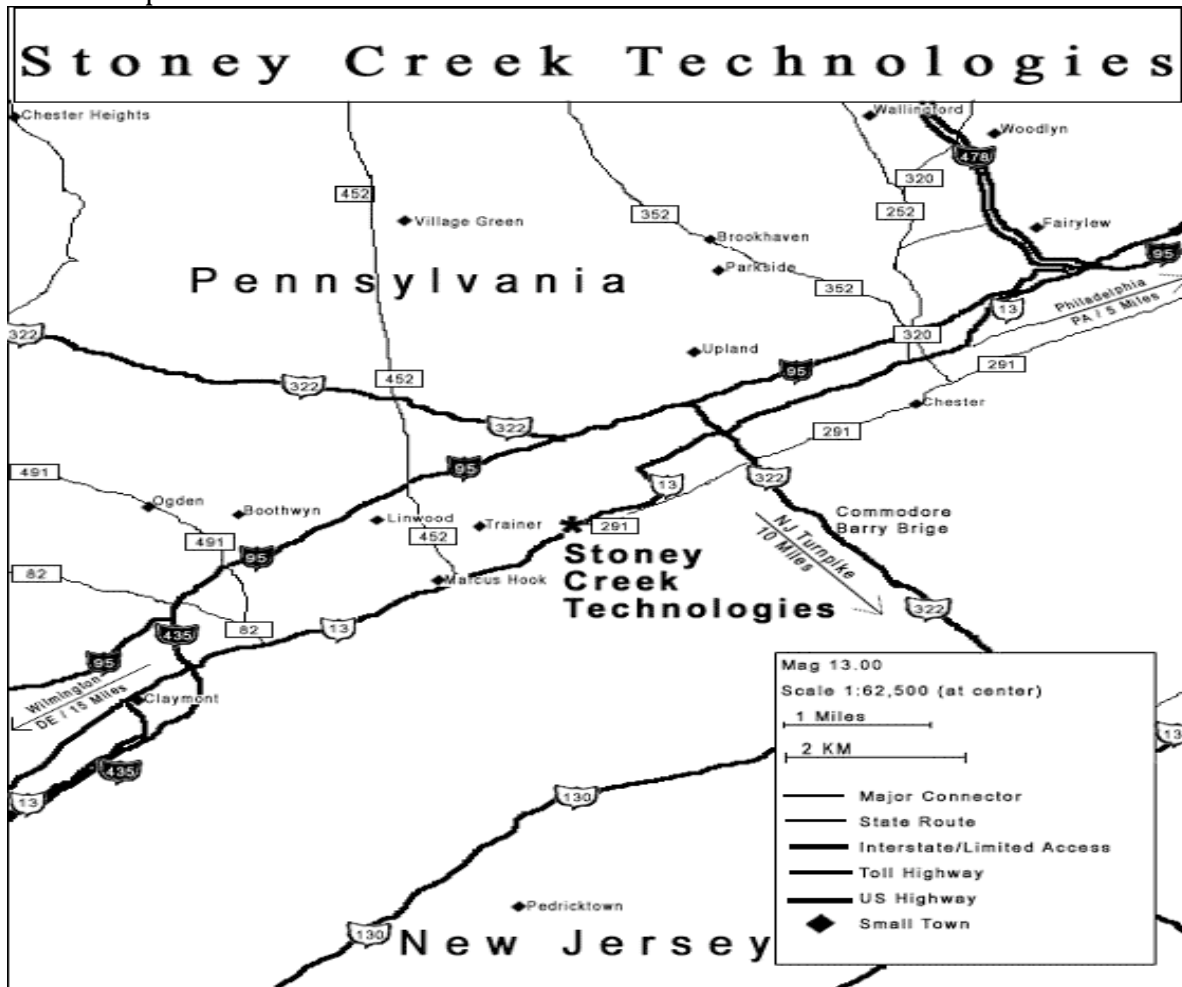

Responsible government offices:

Mike Towle
OSC (On-Scene Coordinator, EPA)
towle.michael@epa.gov

Site Description:

History: Stoney Creek Technologies, LLC is a facility that manufactures base products to be used in corrosion inhibitors, motor oil additives, and grease feed compounds. This company has a history of non-compliance with the Pennsylvania Department of Environmental Protection and on April 12th, 2007, the EPA Region III staff was notified that the facility was facing serious financial difficulties and bankruptcy. The DEP suspended the operating permits and the US EPA became involved on the site to assure that the chemicals at the facility were safeguarded in the absence of the company's ability to do so. The electric company informed Stoney Creek that its electricity has been terminated because of unpaid bills. Without electricity, it was impossible to safely manage

certain chemicals. At this time, an estimated 17 million pound of chemicals were stored on the 15- acre site, adjacent to a residential community.

Nature of the contamination: The Stoney Creek Technologies, LLC facility stores numerous toxic organic compounds for the production of industrial chemicals.

Past and current remediation and development efforts: Starting April 17th, 2007, the PADEP has been paying the electric bill and ensuring that the chemicals on the site are safeguarded. They have been reducing the size of the inventory and as of February 2009, there are 5 million pounds of flammable, combustible, and/or corrosive chemicals, which would pose a substantial risk if improperly handled. Stoney Creek Technologies continues operation on the site to help diminish the amount of chemicals present. Stoney Creek, however, is not currently removing chemical inventory and the EPA has removed 142,000 gallons of chemicals from the site. The operations on the site focus mainly on containment and control of the hazards.

Plans for the future (remediation, development, use): The EPA will continue to remove chemical inventory from the site and evaluate the situation when sufficient inventory is removed or if conditions change so that threats at Stoney Creek are mitigated. Stoney Creek, LLC will continue to work towards financial viability.

Past and present legal actions: Suspension of permits for chemical production by EPA and DEP April, 2007.

Sunoco Inc, Marcus Hook

Delaware and Green Streets, Marcus Hook, PA 19061

Contacts:

EPA Project Manager: Mr. Hon Lee - 3LC30
U.S. Environmental Protection Agency - Region III
1650 Arch Street
Philadelphia, PA 19103-2029
Phone: (215) 814-3419
Email: lee.hon@epa.gov

Mr. Walter Payne
Southeast Regional Office
Pennsylvania Department of Environmental Protection
2 East Main Street
Norristown, PA 19401
Phone: (484) 250-5791

Facility Contact: Jim Oppenheim
Sun Company, Inc.
Phone: (610) 859-1881



Figure 20: Sunoco Marcus Hook Facility (Source: Sunoco Inc)

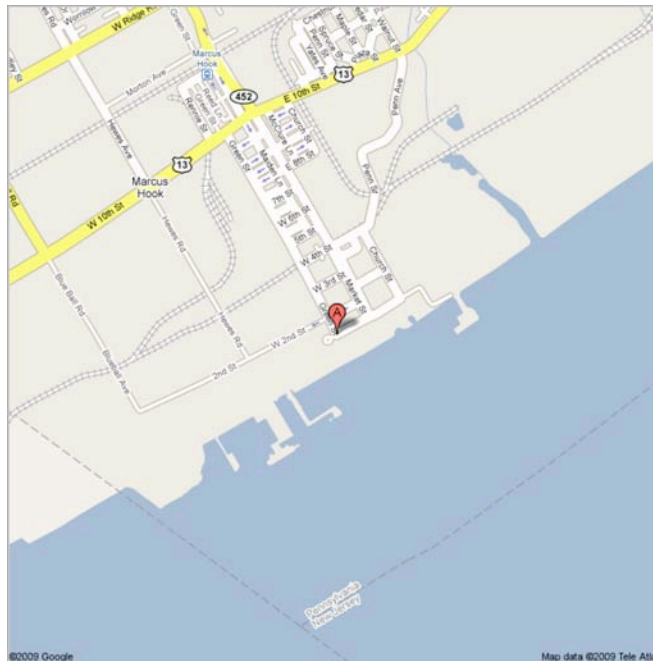

Figure 21: (Source: Google Maps)

Responsible government offices:

PADEP is the responsible government office, enforcing EPA RCRA corrective action mandates.

Site description:

History: The site has been used over time for petroleum refining, processing, and storage. More recently it received permission to operate a hazardous waste storage area. Non-aqueous phase liquid was found in the groundwater at the Facility. In 2000, a 750 MW gas-fired co-generation facility was built on the Phillips Island part of the site. This required a site characterization, remedial investigation, and risk assessment investigation by Sunoco.

Nature of Contamination: Solvent, polyaromatic hydrocarbons, and heavy metals such as lead in the soil and groundwater.

Past and current remediation and development efforts: Sunoco developed a clean-up plan for the Phillips Island portion of the Facility that met the Pennsylvania Land Recycling and Environmental Remediation Standards Act. In 2003, Sunoco took further measures to prevent contaminants from migrating into Middle Creek. This includes a sheet pile wall with 15 pumping wells and 2 recovery wells.

Plans for the future (remediation, development, use): RCRA Corrective Action is being directed by EPA Region 3 with assistance from the state of Pennsylvania. Sunoco submitted a final report under the Land Recycling Program in 2005, maintaining that planned remediation action would attain compliance.

Past and present legal actions: No information available.

C. Hazardous Site Response Action

GE Static Power Site

520 Pusey Ave, Collingdale

Map (Source: Google Maps):



Responsible government offices:

Lynda Rebarchak

Department of Environmental Protection, HSCA listing as Null

Site Description:

History: General Electric owned and operated a Static Electric Power Plant until the 1980's. In 2007 the owner of a neighboring site had his soil tested and found unnaturally high levels of TCE. Subsequent testing in the area showed some level of groundwater and soil contamination, but results are inconclusive and tests are ongoing.

Nature of the contamination: trichloroethylene, an industrial solvent linked to kidney, liver, and nerve damage as well as potential carcinogen.

Past and current remediation and development efforts: No Information Available; likely some internal remediation by GE.

Plans for the future (remediation, development, use): Testing groundwater to determine the extent of the contamination.

Past and present legal actions: None

US Centrifugal HSCA Site

Fifth St & Ellis Ave, Colwyn Borough

Map (Source: Google Maps):

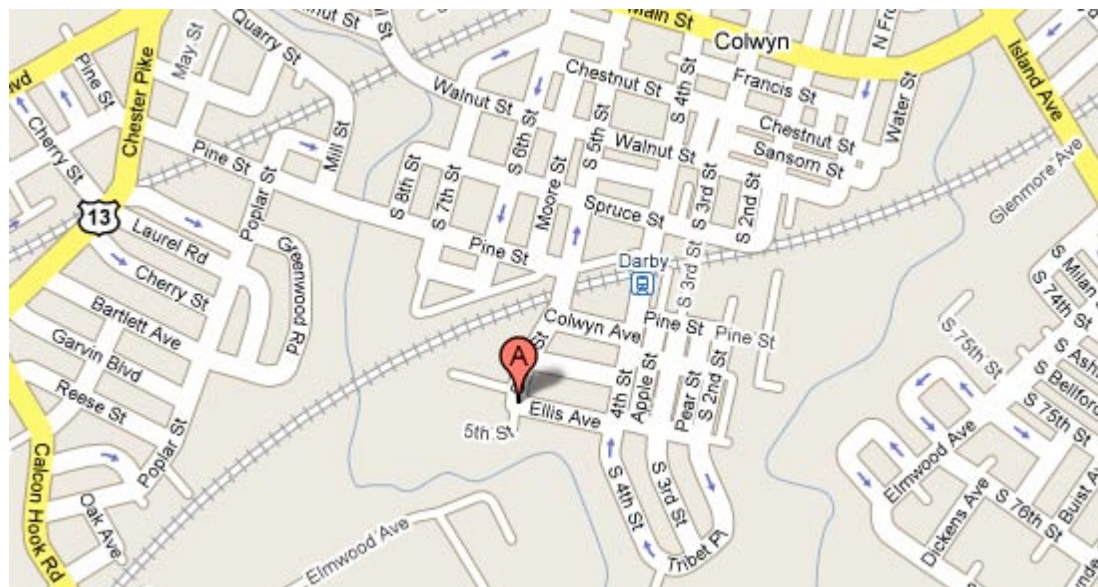

Responsible government offices:

Department of Environmental Protection, Hazardous Site Cleanup Act (HSCA)

Site Description:

History: The 5.5 acre property was a metal foundry and casting site from at least the 1950's until the early 1990's when U.S. Centrifugal went out of business. The bankrupt company left the remaining waste containing lead and other heavy metals onsite. In 1996 the DEP decided to take on the project as part of the HSCA. The remediation included offsite shipment and disposal of the hazardous waste at a cost of \$310,000 to prevent groundwater contamination. The cleanup was finished by 1997. The current use and ownership of the land is unknown.

Nature of the contamination: Lead and other heavy metals.

Past and current remediation and development efforts: In 1996 a cleanup of the waste was performed at a cost of \$310,000.

Plans for the future (remediation, development, use): No information available.

Past and present legal actions: None; the company was bankrupt.

D. Federal Military Cooperative Multi-Site Agreement

The military brownfield sites investigated in this report were all formerly a part of the Cooperative Multi-Site Agreement (CMSA) between the Pennsylvania Department of Environmental Protection (PA-DEP) and the United States Department of Defense (DoD). Drafted in July 1998, the CMSA was designed to assess, prioritize, and remediate contaminated military sites in Pennsylvania. The PA-DEP is in the process of closing out the CMSA, as all of the Army, Navy, Air Force, and Defense Logistics Agency sites have been reviewed under the agreement. Out of the 1098 sites identified in the agreement, over 611 were resolved. The PA-DEP is in the process of converting the agreement into a Formerly Used Defense Sites (FUDS) Management Action Plan, as there are approximately 40 sites that will undergo remedial investigation by the DoD's Defense Environmental Restoration Program (DERP). The four sites investigated in this report are among those 40 that are currently being evaluated by the DERP to determine further investigation or remediation needs.

Air Force Reserve Command (AFRC) Folsom

Ridley Township, along State Route 452

Responsible government offices:

DoD: Defense Environmental Restoration Program (DERP)
Marines (Navy Department)

Site Description:

History: This site is still an active AFRC training facility.

Nature of the contamination: This is a Scheduled Site that still needs to be evaluated for potential hazards. However, in the PA-DOD report, the site is named with "Oil/Grease UST" appended to its AFRC name³⁹. This may indicate the storage of oil or grease in an underground storage tank (UST), which is a potential environmental risk.

Past and current remediation and development efforts:
Four site cleanup actions were completed in 2001 under the CMSA, and currently no further cleanup is required. It is unclear what these specific cleanup actions were.

Plans for the future (remediation, development, use): From the PA-DOD report⁴⁰: This site is classified as a "Scheduled Site," meaning that it has "undergone environmental evaluation, is eligible for funding from the responsible military component's environmental restoration account, and has a tentative remediation schedule covering the 12-year period of the CMSA." The remediation plan is not described in the report. The PA-DOD report also writes that "If still in use, move to Deferred List." Deferred sites are those that are "not addressed under the CMSA," and include "National Priority List (NPL) sites, all sites or

³⁹ PA-DOD, 2006.

⁴⁰ PA-DOD, 2006.

installations listed under the Base Realignment and Closure (BRAC) Program, Resource Conservation and Recovery Act (RCRA) Corrective Action sites, Comprehensive Environmental Response, Compensation and Liability Act (CERCLA) sites and other sites where military responsibility has not been established.” As of 2008, the Hazardous Sites Cleanup Fund Annual Report lists this site as a CMSA site deferred to another program for remediation⁴¹. Possibly starting in 2007, the Defense Environmental Restoration Program (DERP) of the Department of Defense has taken on this site for cleanup⁴². Funding is supplied by the Formerly Used Defense Sites (FUDS) account, in which the Folsom site is classified under the Installation Restoration Program (IRP). Sites in these programs are those that may contain hazardous and low-level radioactive waste. This site is not classified as part of the Military Munitions Response Program (MMRP), which consists of sites containing munitions and explosives of concern. As of 2007, seven IRP sites have been evaluated, though it is unclear what results were found. At this point, there is no planned progress or funding for this site through 2009.

Past and present legal actions: Since the CMSA has been completed, further environmental evaluations of the AFRC Folsom will be conducted by the DERP of the DOD. If cleanup activities are required, the Marines (Navy Dept.) will be held responsible.

Nike Bat PH-67

Site ID=C03PA0229 and C03PA022902
Aston Borough and Chichester Township

Responsible government offices:

DoD: Defense Environmental Restoration Program (DERP)
US Army Corps of Engineers

Site Description:

History: Former Nike Missile Battery, housed the control and launch sites. The entire site originally consisted of 25.98 acres, and was reported to the General Services Administration in December 1964. The entire site was then turned over to the Department of Health, Education and Welfare (HEW) in 1965. The HEW conveyed the former control area, consisting of 11.39 acres, to the Penn-Delco Union School District of Delaware County. This area has since been used as a bus dispatch and maintenance area by the school district. The HEW conveyed the launch area of the site, consisting of 14.59 acres, to the Upper Chichester Township School District of Delaware County. The site was used to build the Hilltop Elementary school grounds.

⁴¹ PA DEP, 2008.

⁴² DERP, 2007.

Nature of the contamination: Two sites have been evaluated, and two more IRP sites were identified.

Past and current remediation and development efforts: Two sites have been designated for “study,” one for “design,” and another for “long-term management” (LTM)⁴³. The specifics for these plans are not given. Throughout 2007, \$173 was spent on these sites for undisclosed purposes.

Plans for the future (remediation, development, use): No additional funding was allotted for 2008-2009 according to the 2007 Annual Report to Congress. The PA DEP is hopeful that this site will be next to undergo additional remedial investigation by the U.S. Army Corps of Engineers.

Past and present legal actions: Since the CMSA has been completed, the site has been categorized as a Formerly Used Defense Site (FUDS). Further environmental evaluations and cleanup activities will be conducted by the US Army Corps of Engineers.

Nike Bat PH-75/78

Site ID= C03PA023002 and C03PA023003
Edgemont and Willistown Townships along Route 3

Photo:



• Figure 4 - Former NIKE Control Area

(from the PA-DOD Multi-Site Agreement Biannual Reports 2002/2003 and 2004/2005)

⁴³ DERP, 2007.

Responsible government offices:

DoD: Defense Environmental Restoration Program (DERP)
US Army Corps of Engineers

Site Description:

History: Former control area of the NIKE Missile Battery, housing the radar equipment. Most of the former NIKE site is now owned by the Willistown township. The Pennsylvania Department of Transportation owns 2.02 acres, and a private citizen owns another 2.71 acres. A portion of the control area is located on the property of the USARC Edgemont (see next case study).

Nature of the contamination: The DERP has identified a total of five sites, and as of 2007, only two of those have been evaluated and three have been designated under IRP⁴⁴. It is unclear what the investigation findings are.

Past and current remediation and development efforts: No information found.

Plans for the future (remediation, development, use): The DERP Report to Congress has identified two sites for “study,” another two for “remedial action construction” (RA-C), and one site for “design.” The DERP spent \$1953 on the sites in 2007, and planned to spend \$445 in 2008 and \$621 in 2009⁴⁵. It is unclear what the funding was specifically for. The site is currently undergoing remedial investigation by the U.S. Army Corps of Engineers.

Past and present legal actions: Since the CMSA has been completed, the site has been categorized as a Formerly Used Defense Site (FUDS). Further environmental evaluations and cleanup activities will be conducted by the US Army Corps of Engineers.

USARC Edgemont (02 NIKE Site)

2101 Delchester Road
Edgemont, PA 19028

⁴⁴ DERP, 2007.

⁴⁵ DERP, 2007.

Photos:



USARC Edgemont: former 223 Motor Pool
(from <http://bobmoran.net/223/223tc.htm>)

Responsible government offices:

DoD: Defense Environmental Restoration Program (DERP)
US Army Corps of Engineers
US Army Reserve Command (99th RRC)

Site Description:

History: This site was one of three former Nike Missile launch areas that were converted to USARC facilities. One of these sites was the former launch site of the NIKE battery, located across the street from the former Nike Bat PH-75/78 control area. As a part of the USARC, this site housed the 223rd Transportation Company activated in 1956 to support the needs of the 79th Army Reserve Command by transporting personnel and light cargo. In 1994, the unit was reorganized into a petroleum transport company. This site is still an active Army Reserve center, currently being utilized as a vehicle storage and maintenance area.

Nature of the contamination: Site investigation revealed no evidence of contaminant release from the launch area. Characterization was based on soil samples around the launch area and water from a single monitoring well.

Past and current remediation and development efforts: No information found.

Plans for the future (remediation, development, use): The PA-DOD report states that additional characterization may be needed, as the presence of only one monitoring well

makes the evaluation of groundwater contamination difficult⁴⁶. However, this progress will need to be prioritized with other sites and may be limited due to funding constraints. This site is classified as a Scheduled Site,” meaning that it has “undergone environmental evaluation, is eligible for funding from the responsible military component’s environmental restoration account, and has a tentative remediation schedule covering the 12-year period of the CMSA.” The remediation plan is not described in the report. As of 2008, the Hazardous Sites Cleanup Fund Annual Report lists this site as a CMSA site deferred to another program for remediation⁴⁷.

Possibly starting in 2007, the Defense Environmental Restoration Program (DERP) of the Department of Defense has taken on this site for cleanup. Funding is supplied by the Formerly Used Defense Sites (FUDS) account, in which the Edgemont site is classified under the Installation Restoration Program (IRP). Sites in these programs are those that may contain hazardous and low-level radioactive waste. This site is not classified as part of the Military Munitions Response Program (MMRP), which consists of sites containing munitions and explosives of concern. As of 2007, fifteen IRP sites have been evaluated, though it is unclear what results were found⁴⁸. At this point, there is no planned progress or funding for this site through 2009.

Past and present legal actions: Since the CMSA has been completed, further environmental evaluations of the USARC Edgemont will be conducted by the DERP of the DOD. If cleanup activities are required, the USARC (99th RRC) will be held responsible. The portion of the site that was formerly a part of the Nike PH-75/78 battery is on publicly and privately owned property, and is considered a Formerly Used Defense Site (FUDS). Remedial investigations conducted at this area is the responsibility of the US Army Corps of Engineers.

⁴⁶ PA-DOD, 2005.

⁴⁷ PA DEP, 2008.

⁴⁸ DERP, 2007

VIII. Summary & Conclusion

In this paper, we outlined the types of brownfields and the general steps in the remediation process. We then discussed the kind of funding available for these projects, as well as the law and policies involved. Subsequently, there was an examination of the technical approaches to dealing with brownfields: outlining site assessment, site investigation, and containment management procedures. Finally, we described the brownfields that are currently known in Delaware County, PA. This includes the sites at which remediation is complete, still active, or where no remediation is taking place. In the same manner of the pivotal environmental justice report of the 2007 Capstone Seminar, we hope that this report will serve as both a reference about general brownfield remediation practice as well as practical document for those looking to gain more information about the status and opportunity for proactive solutions to the brownfields of Delaware County.

Part of the mission of Swarthmore College is to apply knowledge for a greater social good. We, the students of the Environmental Capstone Seminar of Spring 2009, were interested in applying knowledge gained during our college careers to help ameliorate an environmental issue in the surrounding community. Brownfields are an environmental blight on communities that arise through the unsustainable practices by which we live. However, brownfield remediation and redevelopment present a unique opportunity to improve both environmental and economic conditions.

IX. References and Resources

Part I

U.S. Environmental Protection Agency. 2006. "Brownfields Solution Series: Anatomy of Brownfields Redevelopment." October, 2006. www.epa.gov/brownfields/.

U.S. Environmental Protection Agency. 2000. "Superfund: 20 Years of Protecting Human Health and the Environment." Office of Solid Waste and Emergency Response 5204G. www.epa.gov/superfund.

Eben, J. L. Brownfields development more important than ever. 2008. Real Estate Weekly, 11 June. <http://www.allbusiness.com/government/government-bodies-offices/11413937-1.html>.

"Lecture 24: Brownfields and Superfund Reform." Date accessed March 15, 2009. <http://ocw.mit.edu/NR/rdonlyres/Civil-and-Environmental-Engineering/1-34Spring2004/562F3634-8757-4AA2-A564-64CA9EE22245/0/lecture24.pdf>.

Delaware Valley Regional Planning Commission. 2006. "Municipal Implementation Tool #10: Reclaiming Brownfields." <http://regionalgreenplan.org/planning/community/mcdtools/pdf/tool10.pdf>.

National Brownfields Associations (NBA). Press Release. 2009. <http://www.brownfieldassociation.org/Media/tabid/66/Default.aspx>.

Pennsylvania Office of the Governor. "Governor Rendell Says PA's Commitment to Housing and Redevelopment Assistance Program Helping Communities, Residents." <http://www.prnewswire.com/cgi-bin/stories.pl?ACCT=104&STORY=/www/story/08-13-2007/0004644728&EDATE>.

Part II

Environmental Protection Agency, National Risk Management Research Laboratory (NRMRL). "Typical Brownfield Sites." <http://www.epa.gov/nrmrl/pubs/625r00009/625R00009chap2.pdf>.

Slocum, Curtis. November 2008. "Buying Brownfields: Opportunity or Risk? Area Development Online." Date accessed 4/1/09. <http://www.areadevelopment.com/siteSelection/nov08/brownfield-sites-environmental-contamination.shtml>.

Part III

U.S. Environmental Protection Agency. "Anatomy of Brownfields Redevelopment: EPA-560-F-06-245." 2006. www.epa.gov/brownfields/.

Reddy, K. R., Adam, J. A. & Richardson, C. 1999. "Potential Technologies for Remediation of Brownfields." *Practice Periodical of Hazardous, Toxic, and Radioactive Waste Material*, 61-69.

U.S. Environmental Protection Agency. 2001. "Technical Approaches to Characterizing and Cleaning up Brownfield Sites." Technology Transfer and Support Division National Risk Management Research Laboratory. www.epa.gov/nrmrl/pubs/625r02007/625R02007.pdf

Part IV

National Funding Sources:

Kathryn Whiteman, "Brownfields Funding and Technical Assistance Sources." Date Accessed 20 March, 2009. http://www.kdheks.gov/brownfields/download/bf_update.pdf.

EPA, Brownfields. (2008) "Funding and Financing for Brownfields." Date Accessed 26 March, 2009. <http://epa.gov/brownfields/mmatters.htm>.

State Funding Sources:

DEP, Office of Community Revitalization and Local Government Support. "Brownfield Revitalization" Date Accessed 27 March, 2009. <http://www.depweb.state.pa.us/ocrlgs/cwp/view.asp?a=1459&Q=517261>.

County Funding Sources:

Delaware County Renaissance Program Resource Guide (2006) "Section 1: Brownfield Guide." Date Accessed 27 March, 2009. <http://www.co.delaware.pa.us/planning/countyregionalplanning/Section%201%20Brownfields.pdf>

Non-Profit Funding Sources:

National Brownfield Association. (2009) "About the NBA & NBA Canada." Date Accessed 26 March, 2009. <http://www.brownfieldassociation.org/AboutUs/tabid/53/Default.aspx>.

Northeast-Midwest Institute. (2009) "Brownfields." Date Accessed 26 March, 2009. <http://www.nemw.org/brownfields.htm>.

Part V

- Abdel-Aziz, A. (2002) "Reclaiming Contaminated Lands: Resolving the Brownfields Stalemate in Canada." Osler Outlook. Date Accessed 1 May, 2009.
<http://www.osler.com/resources.aspx?id=8530>.
- Beck, E. C. (1979) "The Love Canal Tragedy." EPA History. Date Accessed 3 March, 2009.
<http://www.epa.gov/history/topics/lovecanal/01.htm>
- Bourdeau, Karl S. (2002) New Brownfields Law Will Affect Transactions Of Potentially Contaminated Property. <http://bdlaw.com/assets/attachments/50.pdf>
- Comprehensive Environmental Response, Compensation, and Liability Act (CERCLA), 2004. Section 107 (House of Representatives).
- Davis, Todd S. (2002) Brownfields: A Comprehensive Guide to Redeveloping Contaminated Property. Section of Environment, Energy and Resources American Bar Association.
- EPA, Brownfields. (2008) "About Brownfields." EPA Basic Information.
<http://epa.gov/brownfields/about.htm>
- EPA Press Release. (1981) "EPA Schedules Emergency Cleanup at Valley of the Drums" EPA History. <http://www.epa.gov/history/topics/drums/01.htm>
- Hoehn, M. (2002) "The Impact of Location and Contamination Type on Brownfield Remediation and Redevelopment." The College of New Jersey Economics/Business. Date Accessed 2 May, 2009.
www.tcnj.edu/~business/economics/documents/hoehn.TCNJ.pdf
- MIT. (2004) Hazardous Waste Regulations and Hazardous Materials.
<http://ocw.mit.edu/NR/rdonlyres/Civil-and-Environmental-Engineering/1-34Spring2004/FD3EA347-E364-4AF8-95BA-044E2DBE34B4/0/lecture02.pdf>
- Pennsylvania Department of Environmental Protection. "Uniform Environmental Covenants Act – UECA." Date Accessed 5 April, 2009.
<http://www.depweb.state.pa.us/ocrlgs/cwp/view.asp?a=1459&Q=534040>
- State Environmental Resource Center (SERC). (2002) "Features of Good Brownfields Legislation." Cleaning up Brownfields: Policy Issues Package. Date Accessed 8 April, 2009. <http://www.serconline.org/brownfields/legislation.html>
- U.S. Environmental Protection Agency. 2001. "Technical Approaches to Characterizing and Cleaning up Brownfield Sites." Technology Transfer and Support Division National Risk Management Research Laboratory.
www.epa.gov/nrmrl/pubs/625r02007/625R02007.pdf

Part VI

ASTM. 2005. Section 11: Water and Environmental Technology *in* Annual Book of ASTM Standards, Volume 11.04.

Berstein, M. 2006. Industrial Archaeology and Environmental Assessments. *Industrial Archaeology* **32**: 25-51.

EPA. CERCLIS Database: Superfund Information Systems. 31 July 2008.
<<http://www.epa.gov/superfund/sites/cursites/>>. [accessed 2009 April 19].

EPA. Contaminated Site Clean-Up Information. <<http://clu-in.org/>>. [accessed 2009 April 19].

EPA. 2001. Technical Approaches to Characterizing and Cleaning up Brownfields Sites. US Environmental Protection Agency, EPA-652-R-00-009.

EPA. 2005. Road Map to Understanding Innovative Technology Options for Brownfields Investigation and Cleanup, fourth ed. US Environmental Protection Agency, EPA-542-B-05-001.

Part VII

Austin Avenue Radiation

Environmental Protection Agency. (2008) Site Progress Profile.
<http://cfpub1.epa.gov/supercpad/cursites/csitinfo.cfm?id=0304433>

South Eastern Pennsylvania Transit Authority. (1990) Eastern Delaware County Map with EPA van radius overlay. <http://loggerhead.epa.gov/arweb/public/pdf/102690.pdf>

BP Oil

Environmental Protection Agency. (2008) Progress Report on BP Oil Marcus Hook Site.
<http://www.epa.gov/reg3wcmd/ca/pa/pdf/pad071612683.pdf>

MCDERMOTT, M. (2004) Tanker Explosion Rocked the Hook. News of Delaware County. http://www.zwire.com/site/news.cfm?newsid=13515627&BRD=1725&PA G=461&dept_id%09=45529&rfi=6

ROMANEK, A. (1999) Building the Foundation for Environmental Risk Assessment at the Marcus Hook Refinery Using Geographic Information System. Civil Engineering Department, University of Texas.
<http://www.ce.utexas.edu/prof/maidment/grad/romanek/research/thesis.pdf>

Congoleum

Environmental Protection Agency. (2008) Progress Report on Congoleum Marcus Hook Site. <http://www.epa.gov/reg3wcmd/ca/pa.htm>

East Coast Chemical Disposal, Inc.

Environmental Protection Agency. (2008) Progress Report on East Coast Chemical Disposal, Inc. Marcus Hook Site.

<http://www.epa.gov/reg3wcmd/ca/pa.htm>

General Chemical Corp.

Environmental Protection Agency. (2008) Progress Report on General Chemical Corp. Marcus Hook Site.

<http://www.epa.gov/reg3wcmd/ca/pa.htm>

Hilltop Residential Lab

<http://www.epa.gov/reg3hwmd/super/sites/PASFN0305565/index.htm>

Oil Tank Lines, Inc.

<http://www.epa.gov/reg3hwmd/super/sites/PA0001909522/index.htm>

Honeywell International, Inc.

Pennsylvania Salt Service

Environmental Protection Agency. (2008) Administrative Record

http://loggerhead.epa.gov/arweb/public/search_results.jsp?siteid=PAD987387578

Stoney Creek Technologies LLC

EPA reports on Stoney Creek:

www.epaosc.net/stoneycreek

<http://www.ercweb.com/resources/viewtip.aspx?id=6964>

Stoney Creek, LLC website:

<http://www.sctsaci.com/>

PECO Energy Co., Chester Facility

EPA reports on the PECO Energy Co., Chester Facility:

www.epa.gov/reg3wcmd/ca/pa/pdf/pad000731026.pdf

www.epa.gov/reg3wcmd/ca/pa/hhpdf/hh_pad000731026.pdf

WADE (AMB)

Report on the Wade (AMB) site:

<http://www.epa.gov/reg3hwmd/npl/PAD980539407.htm>

Beyond the Flames, exposé by the Philadelphia Inquirer Staff:

<http://inquirer.philly.com/specials/2000/fire/>

USARC Edgemont

From the Defense Environmental Restoration Program: Annual Report to Congress for Fiscal Year 2007:

<http://deparc.xservices.com/do/generateReport?ffid=PA321042146500&detail=1&reportFormat=B1>

PA-DOD Multi-Site Agreement Biannual Reports 2002/2003 and 2004/2005

PA DEP Hazardous Sites Cleanup Fund Annual Report, August 2008

AFRC Folsom

From the Defense Environmental Restoration Program: Annual Report to Congress for Fiscal Year 2007:

<http://deparc.xservices.com/do/generateReport?ffid=PA32104PA02800&detail=1&reportFormat=B1>

PA-DOD Multi-Site Agreement Biannual Reports 2002/2003 and 2004/2005

PA DEP Hazardous Sites Cleanup Fund Annual Report, August 2008

Nike Bat PH-75/78

From the Defense Environmental Restoration Program: Annual Report to Congress for Fiscal Year 2007:

[http://deparc.xservices.com/do/searchInstallationResult?ffid=PA39799F146600&installationName=NIKE%20PH-75/78%20\(MEDIA\)&stateCode=PA&servName=FORMERLY%20USED%20DEFENSE%20SITES&programFundCode=&fundSource=&bracStatus=](http://deparc.xservices.com/do/searchInstallationResult?ffid=PA39799F146600&installationName=NIKE%20PH-75/78%20(MEDIA)&stateCode=PA&servName=FORMERLY%20USED%20DEFENSE%20SITES&programFundCode=&fundSource=&bracStatus=)

PA DEP Hazardous Sites Cleanup Fund Annual Report, August 2008

Nike Bat PH-67

From the Defense Environmental Restoration Program: Annual Report to Congress for Fiscal Year 2007:

<http://deparc.xservices.com/do/generateReport?ffid=PA39799F146500&detail=1&reportFormat=B1>

PA DEP Hazardous Sites Cleanup Fund Annual Report, August 2008

Superfund Site Description: Havertown PCP

Agency for Toxic Substances & Disease Registry

<http://www.atsdr.cdc.gov/toxprofiles>

“Challenges to Redevelopment near Haverford PCP Site.” Philly.com.

http://www.philly.com/philly/news/local/20081124_Haverford_balks_at_price_to_buy_former_gum_factory.html

Environmental Protection Agency. Haverton PCP Cleanup Actions.

<http://cfpub.epa.gov/supercpad/SiteProfiles/index.cfm?fuseaction=second.CleanupActs&id=0300574>

Environmental Protection Agency. Havertown PCP Contaminants of Concern.

<http://cfpub.epa.gov/supercpad/SiteProfiles/index.cfm?fuseaction=second.contams&id=0300574>

Environmental Protection Agency. Havertown PCP Superfund Site Progress Profile.

<http://cfpub.epa.gov/supercpad/cursites/csitinfo.cfm?id=0300574>

Green Remediation: Havertown PCP Site. http://www.clu-in.org/greenremediation/subtab_d9.cfm

Havertown PCP Superfund Wikipedia Page.

http://en.wikipedia.org/wiki/Havertown_Superfund

Boeing Company CTR South

“Boeing completes first cleanup under Pa-federal Brownfield Program”. 30 March, 2006.

Waste & Recycling News. Date accessed: 2 April, 2009.

<http://www.wasterecyclingnews.com/headlines2.html?id=1143756322>

HANNA, J. “A Catalyst to Revitalization at RCRA Corrective Action Sites in Pennsylvania: the PA One Cleanup Program.” Presentation on 17 April, 2008 for the Engineers’ Society of Western Pennsylvania 13th Annual Business of Brownfields Conference in Pittsburgh. Accessed 31 March, 2009.

<http://www.eswp.com/brownfields/Hanna%20Jason.pdf>

Lower Darby Creek Area

EPA. “Lower Darby Creek.” Accessed 3/15/09

<http://www.epa.gov/reg3hwmd/super/sites/PASFN0305521/index.htm>

EPA. June 2001. “NPL Listing Package for the Lower Darby Creek Area.” Accessed 3/15/09

<http://www.epa.gov/reg3hwmd/super/sites/PASFN0305521/hrs/2001-06.pdf>

Hazardous Waste Superfund Alert. December 4, 2006. “EPA, 14 Parties agree to investigate cleanup option at Folcroft Landfill.” Accessed 3/15/09

http://www.dupontsafetyrevealed.org/News/Folcroft_landfill.htm

Sackville Mills Property

EPA. “Sackville Mills Administrative Records on the Web.” Accessed 3/15/09

http://loggerhead.epa.gov/arweb/public/search_results.jsp?siteid=PA0000198846#

Marcus Hook Wastewater Treatment Facility MHPI

EPA. February 19, 2008. "Marcus Hook Wastewater Treat Fac. MHPI." Accessed 3/15/09
<http://www.epa.gov/reg3wcmd/ca/pa/pdf/pad098160906.pdf>

EPA. "Marcus Hook Wastewater Treat Fac MHPI." Accessed 3/15/09
http://oaspub.epa.gov/enviro/rcra_profile.getmain?p_handler_id=PAD098160906

EPA. "Facility Location Information." Accessed 3/15/09
http://oaspub.epa.gov/enviro/lrt_viewer.map_page?sys_acrnm=RCRAINFO&sys_id=PAD098160906

National Oceanic and Atmospheric Administration, Office of Response and Restoration.
"FMC Marcus Hook, aka East Tenth St. Industrial Area." Coastal Hazardous Waste
Site Review. Accessed 3/15/09
http://response.restoration.noaa.gov/book_shelf/439_FMC_Marcus_Hook.pdf

GE Static Power Site

Petitti, Michael. 18 November, 2008. "Former GE plant labeled hazardous." *Delco Times*.
Date Accessed 20 March, 2009.
<http://www.delcotimes.com/articles/2008/11/19/news/doc49238ed1c4b14065904835.txt>

US Centrifugal HSCA Site

The Pennsylvania Bulletin. *Number 26 Pa.B. 2829* (1996). "U. S. Centrifugal Site: Colwyn
Borough Delaware County" Date Accessed 20 March, 2009.
<http://www.pabulletin.com/secure/data/vol26/26-24/971b.html>

East Tenth St.

Environmental Protection Agency. (2009) "East Tenth Street." Mid-Atlantic Superfund Site
Progress Report. Date Accessed 21 March, 2009.
<http://www.epa.gov/reg3hwmd/super/sites/PAD987323458/index.htm>

Scorecard: The Pollution Information Site. (2005) "Superfund Site Report: EAST TENTH
STREET." Date Accessed 20 March, 2009.
http://www.scorecard.org/env-releases/land/site.tcl?epa_id=PAD987323458#maps

Sunoco Inc, Marcus Hook

Environmental Protection Agency. (2008) Site Progress Report
<http://www.epa.gov/reg3wcmd/ca/pa/pdf/pad980550594.pdf>